



# Installation Guide

## **Mini-OTE 300** **Optical Terminal Enclosure**



# Mini-OTE 300

## Optical Terminal Enclosure



## Preface

---

This preface provides an overview of the Mini-OTE 300 *Installation Guide*, describing guide conventions and listing other publications that may be useful.

### Introduction

This *Installation Guide*:

- Describes the name and function of the kit contents
- Describes how to prep cable
- Describes fiber organizing/storage, routing and splicing
- Describes grounding/organization procedure
- Describes cable retention procedure
- Describes how to close and secure terminal enclosure
- Describes how to mount the terminal enclosure for pedestal, hand hole, pole and strand mount applications
- Describes installation of hardened connectors and adapters



#### Notice

You can download or request the latest documents and information on CommScope Inc. from the website <http://www.CommScope.com>

---

## Symbols in this guide

The symbols below are used to indicate product names and notes in this guide.

### Product name

The name of the product is Mini-OTE 300.

### Description of symbols

The *Installation Guide* uses the following icons and fonts to indicate special messages for the reader.



Note

Presents useful information related to *Installation Guide* contents, the references and data related to the product's use, etc.



Caution

Describes situations where data loss and incorrect product operation may occur, and provides proper actions to take in these situations.





# Organization and Table of Contents

---

The *Installation Guide* consists of 10 chapters. A summary of each part is given below.

## **Chapter 1. Introduction.....1**

---

This chapter introduces the Mini-OTE 300 product, kit contents and required tools for installation and supplementary kits available for use with the Mini-OTE 300.

### **Overview**

Cable Types.....	1
Tools Required.....	1
Main Functions and Features .....	2

## **Chapter 2. Installation Preparation.....3**

---

This chapter discusses the items necessary to install the Mini-OTE 300 and also provides helpful notes to consider during installation and use of the product. To prevent any problem that may occur during installation, the user should fully understand this information before installing the product.

<b>Notes to consider before installation.....</b>	<b>4</b>
Do not disassemble the product .....	4
Installation site condition .....	4
Components Required .....	5
Supplementary Kit .....	6

## **Chapter 3. Inline Express - LBT Standard and Micro, Flat Drop with/without trace .....7**

---

This chapter discusses cable preparation, grounding, cable retention, fiber organizing/storage, routing and splicing for **Inline Express for Loose Buffer Tube (LBT) Standard and Micro cables, Flat Drop with/without trace wire**. It also provides helpful notes to consider during installation and use of the product. To prevent any problem that may occur during installation, the user should fully understand this information before installing the product.

3.1 Cable Preparation .....	7
3.2 Cable and External Grounding .....	9
3.3 Cable Retention .....	10
3.4 Fiber Organizing/Storage, Routing and Splicing .....	12
3.5 Closing/Securing Closure .....	14
3.6 Mounting Closure .....	15



**Chapter 4. Butt Express - LBT Standard and Micro,  
Flat Drop with/without trace.....16**

---

This chapter discusses cable preparation, grounding, cable retention, fiber organizing/storage, routing and splicing for **Butt Express for LBT Standard and Micro cables, Flat Drop with/without trace wire**. It also provides helpful notes to consider during installation and use of the product. To prevent any problem that may occur during installation, the user should fully understand this information before installing the product.

- 4.1 Cable Preparation .....16
- 4.2 Cable and External Grounding .....18
- 4.3 Cable Retention .....19
- 4.4 Fiber Organizing/Storage, Routing and Splicing .....21
- 4.5 Closing/Securing Closure .....23
- 4.6 Mounting Closure .....24

**Chapter 5. Inline Stub - LBT Standard and Micro,  
Flat Drop with/without trace.....25**

---

This chapter discusses cable preparation, grounding, cable retention, fiber organizing/storage, routing and splicing for **Inline Stub for LBT Standard and Micro cables, Flat Drop with/without trace wire**. It also provides helpful notes to consider during installation and use of the product. To prevent any problem that may occur during installation, the user should fully understand this information before installing the product.

- 5.1 Cable Preparation .....25
- 5.2 Cable and External Grounding .....28
- 5.3 Cable Retention .....29
- 5.4 Fiber Organizing/Storage, Routing and Splicing .....31
- 5.5 Closing/Securing Closure .....33
- 5.6 Mounting Closure .....34

**Chapter 6. Butt Stub - LBT Standard and Micro,  
Flat Drop with/without trace.....35**

---

This chapter discusses cable preparation, grounding, cable retention, fiber organizing/storage, routing and splicing for **Butt Stub for LBT Standard and Micro, Flat Drop with/without trace wire**. It also provides helpful notes to consider during installation and use of the product. To prevent any problem that may occur during installation, the user should fully understand this information before installing the product.



6.1	Cable Preparation .....	35
6.2	Cable and External Grounding .....	37
6.3	Cable Retention .....	38
6.4	Fiber Organizing/Storage, Routing and Splicing .....	40
6.5	Closing/Securing Closure .....	42
6.6	Mounting Closure .....	43

**Chapter 7. Inline Express -  
Ribbon Central Core Tube Shielded/Unshielded.....44**

---

This chapter discusses cable preparation, grounding, cable retention, fiber organizing/storage, routing and splicing for **Inline Express for Ribbon Central Core Tube Shielded and Unshielded cable**. It also provides helpful notes to consider during installation and use of the product. To prevent any problem that may occur during installation, the user should fully understand this information before installing the product.

7.1	Cable Preparation .....	44
7.2	Cable and External Grounding.....	46
7.3	Cable Retention .....	47
7.4	Fiber Organizing/Storage, Routing and Splicing .....	49
7.5	Closing/Securing Closure .....	51
7.6	Mounting Closure .....	52

**Chapter 8. Butt Express -  
Ribbon Central Core Tube Shielded/Unshielded .....53**

---

This chapter discusses cable preparation, grounding, cable retention, fiber organizing/storage, routing and splicing for **Butt Express for Ribbon Central Core Tube Shielded and Unshielded cable**. It also provides helpful notes to consider during installation and use of the product. To prevent any problem that may occur during installation, the user should fully understand this information before installing the product.

8.1	Cable Preparation .....	53
8.2	Cable and External Grounding .....	55
8.3	Cable Retention .....	56
8.4	Fiber Organizing/Storage, Routing and Splicing .....	57
8.5	Closing/Securing Closure .....	59
8.6	Mounting Closure .....	60





**Chapter 9. Inline Stub -  
Ribbon Central Core Tube Shielded/Unshielded .....61**

---

This chapter discusses cable preparation, grounding, cable retention, fiber organizing/storage, routing and splicing for **Inline Stub for Ribbon Central Core Tube Shielded and Unshielded cable**. It also provides helpful notes to consider during installation and use of the product. To prevent any problem that may occur during installation, the user should fully understand this information before installing the product.

- 9.1 Cable Preparation .....61
- 9.2 Cable and External Grounding .....63
- 9.3 Cable Retention .....64
- 9.4 Fiber Organizing/Storage, Routing and Splicing .....66
- 9.5 Closing/Securing Closure .....68
- 9.6 Mounting Closure .....69

**Chapter 10. Butt Stub -  
Ribbon Central Core Tube Shielded/Unshielded .....70**

---

This chapter discusses cable preparation, grounding, cable retention, fiber organizing/storage, routing and splicing for **Butt Stub for Ribbon Central Core Tube Shielded and Unshielded cable**. It also provides helpful notes to consider during installation and use of the product. To prevent any problem that may occur during installation, the user should fully understand this information before installing the product.

- 10.1 Cable Preparation .....70
- 10.2 Cable and External Grounding .....73
- 10.3 Cable Retention .....74
- 10.4 Fiber Organizing/Storage, Routing and Splicing .....75
- 10.5 Closing/Securing Closure .....77
- 10.6 Mounting Closure .....78

**Chapter 11. Installation and Cleaning of Connectors and Adaptors  
DLX and Optitap Drop.....79**

---

- 11.1 Connecting Drop Cable to Mini OTE Optical Port..... 80
- 11.2 Disconnecting Drop Cable From Mini OTE Port ..... 81
- 11.3 Maintenance of Mini-OTE 300 Terminals .....81
- 11.4 Drop Cable Connector Cleaning Procedure .....81
- 11.5 Mini-OTE Adapter/Connector Cleaning Procedure ..... 83
- 11.6 O-Ring Lubrication..... 83



## List of tables

---

Table 1. Maximum Number of Splices per Configuration .....2

## List of Figures

---

Figure 1. Inline Express LBT Standard and Micro, Flat Drop with/without trace wire  
Mid-Span Opening.....7

Figure 2. Inline Express LBT Standard and Micro, Flat Drop with/without trace wire  
Buffer Tube Removal .....8

Figure 3. Butt Express LBT Standard and Micro, Flat Drop with/without trace wire  
Mid-Span Opening .....16

Figure 4. Butt Express LBT Standard and Micro, Flat Drop with/without trace wire  
Buffer Tube Removal .....17

Figure 5. Inline Stub LBT Standard and Micro, Flat Drop with/without trace wire  
Cable End Prep .....25

Figure 6. Inline Stub LBT Standard and Micro, Flat Drop with/without trace wire  
Buffer Tube Removal, Cable Entry Right .....27

Figure 7. Inline Stub LBT Standard and Micro, Flat Drop with/without trace wire  
Buffer Tube Removal, Cable Entry Left .....27

Figure 8. Butt Stub LBT Standard and Micro, Flat Drop with/without trace wire  
Cable End Prep .....35

Figure 9. Butt Stub LBT Standard and Micro, Flat Drop with/without trace wire  
Buffer Tube Removal.....36

Figure 10. Inline Express Ribbon Central Core Tube Shielded/Unshielded  
Mid-Span Opening.....44

Figure 11. Butt Express Ribbon Central Core Tube Shielded/Unshielded  
Mid-Span Opening.....53

Figure 12. Inline Stub Ribbon Central Core Tube Shielded/Unshielded  
Cable End Prep.....61

Figure 13. Butt Stub Ribbon Central Core Tube Shielded/Unshielded  
Cable End Prep.....70

# Chapter 1. Introduction

This chapter introduces the Mini-OTE 300 and various cable types the terminal enclosure accommodates in FTTx deployments.

The chapter consists of the following:

- Cable Types
- Tools Required
- Main functions and features

## General Product Information

CommScope's Mini-OTE 300 closure is a gel sealed fiber optic terminating enclosure designed for the telecom outside plant network. The closure is available in 2, 4, 6, 8 and 12 port versions with full-size or mini-size DLX ® hardened adapters with options for factory installed splitter or CWDM. The closure has a maximum splice capacity of 40 splices. It is suitable for deployment in aerial, pole, pedestal, and below grade applications. The Mini-OTE 300 allows for both in line and butt configurations with 5 ports accepting standard flat drop up to ½" diameter cable for multiple combinations of feeder and drop cables. Sealing is achieved by spring loaded gel technology, resulting in extremely convenient re-entry and resealing.

## Cable Types

The Mini-OTE 300 is designed for standard flat drop, with or without toning wire, and loose buffer tube and central core tube up to ½" diameter cable. Provisions are provided for shielded cable grounding. Fiber types include single fiber 250 micron and ribbon.

## Tools Required

- 7/16" wrench – exterior bolt hardware
- 3/8" wrench – interior bolt hardware and pole mount bracket hardware  
or type 216C can wrench - exterior and interior bolt hardware
- Flathead #2 screwdriver

## Overview

This section describes the functions and features of the Mini-OTE 300 closure

### Main Functions and Features

The Mini-OTE 300 is a unique solution for splicing, termination and pass-through cable requirements in fiber-to-the-x (FTTx) architectures.

- Terminal is re-enter-able, swinging open on a hinge for quick access and easy service and maintenance
- Available with 2, 4, 6, 8 or 12 adapter ports, full-size or mini-size DLX® hardened adapters
- Four gel-sealed input ports for express and branch-off cables for butt installations
- One gel-sealed input port for express and branch-off cables for in-line installations
- Units are shipped with two factory integrated splice trays and a fiber storage tray. Slack cable storage is available beneath the splicing trays.
- Accommodates CommScope’s field installable splitters (1x2, 1x4, 1x8) and field installable compact CWDMs (2, 4, 8 channel).
- Max number of splices
  - NOTE: trays intended for single stranded splice only, ribbon to be deribbonized and spliced as single strands.

Product Configuration	Max # Splices	Tray #1	Tray #2
Without Splitter or CCWDM	40	20 *	20 *
With Splitter	34	14	20 *
With CCWDM	26	6	20 *

\* Requires additional smouv holder ... - .000 for holding six splices

**Table 1**

Without Splitter or CCWDM



With Splitter



With CCWDM



---

## **Chapter 2. Installation Preparation**

This chapter discusses the items necessary to install Mini-OTE 300 and also provides helpful notes to consider during installation and use of the product. To prevent any problem that may occur during installation, the user should fully understand this information before installing the product.

This chapter consists of:

- Notes for installation
- Components required for installation
- Supplementary Kits

## Notes to consider before installation

Before installing and using the Mini-OTE 300, the user should fully understand the warnings and notes explained in this section.

### Do not disassemble the product

The user should not disassemble the product. If the user thinks a repair is necessary, contact the CommScope Technical Support Team (800) 830-5056.

### Installation site condition

For safe and stable use, the product should be installed in a site satisfying the following conditions:

- Install the product in a location where the fiber technician can easily access, connect and disconnect cables to the product.

### Components Required for Installation

For safe and stable use, the product should be installed using the following components found in the Mini-OTE 300 kit.

Item #	Description	Item #	Description
1	Mini-OTE 300 Terminal Enclosure	10	Mini-OTE 300 port plugs (4), ground plug (1)
2	Cable retention hardware assembly (5)	11	Mini-OTE 300 Ribbon standard grommet
3	Bolts for cable retention assembly . 3/8" hex head slotted (6)	12	Mini-OTE 300 LBT standard grommet
4	Inline Ground Bar	13	Mini-OTE 300 LBT micro grommet
5	Ground bar	14	Spiral Wrap 3/8", (2- 1ft.)
6	Cable ties	15	Routing Label
7	Perforated foil (installer must cut in half, to be used on all cables) (3)	16	60 mm SMOUVS (30)
8	Hand hole mounting clamp (2)	17	Pedestal mount optional hardware – SLTD Index Hex Washer machine screw 10/24 x 1" (4) Nut lock washer (4)
9	Hand hole clamp hardware – bolt 7/16 Hex (2)		

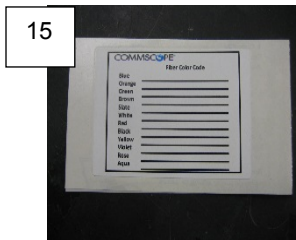
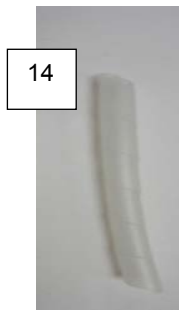
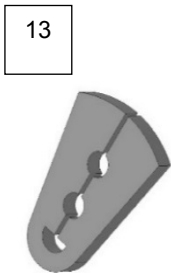
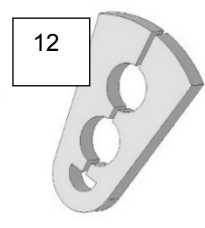
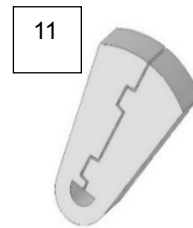
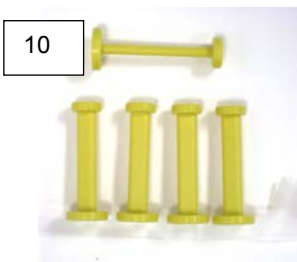
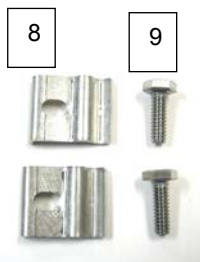
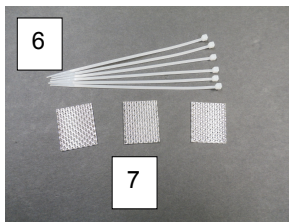

## Supplementary Kits

### Cable Retention Kit: # 760242289

#### OTE-M-CABLERET-KIT

- Cable retention assembly (2)
- Bolt (2)
- Perforated Foil



Included in kits but additional components available in supplementary kit.

### Smouv Holder 6X:

### Strand Clamp Kit: # 760244002

#### OTE-M-STRAND-CLAMP

- Cable clamps (4)
- Bolts (2)



### Pole Mount Kit: # 860634772

#### OTE-M-POLEMNT-BRKT

- Brackets (2)
- Bolts - 7/16" hex head (4)
- Cable ties (2)



### Strand Mount Kit: # 760235507

#### OTE-M-STRAND BRKT

- Brackets with hardware (2)
- Bolts (2)
- Lock Washers (2)





# Chapter 3. Inline Express – LBT Standard and Micro, Flat Drop with/without trace wire

## 3.0 CABLE PREPARATION

### 3.1 Inline Express (Thru) Configuration

3.1.1 Preparation of Loose Buffer Tube Standard or Micro, and Flat Drop with or without Trace wire.  
See Figure 1.

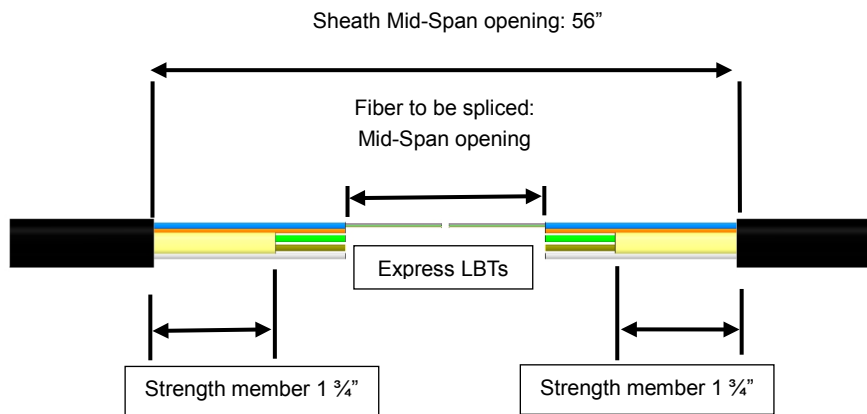

Figure 1

3.1.2 Prepare mid-span opening: remove 56\" of outer sheath. See Figure 1.

3.1.3 Cut strength member(s) 1 3/4\" from end of sheath openings. See Figure 1. If flat drop has a trace wire, cleanly cut away 4\" of wire from end sheath opening. See photos 1-2.

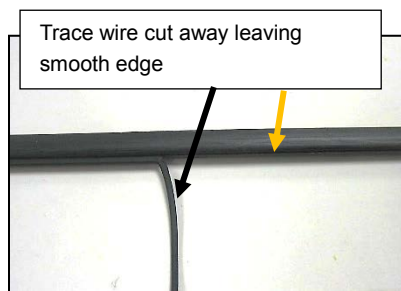

Photo # 1

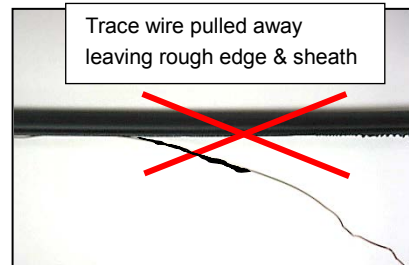

Photo # 2

3.1.4 If cable is shielded and to be grounded proceed to **Section 3.2** Cable and External Grounding.

3.1.5 Proceed to **Section 3.3** to assemble cable retention hardware to each cable end opening.

3.1.6 Separate buffer tube (s) containing fibers to be spliced from LBT bundle.

3.1.7 Snap cable retention assemblies into the appropriate locations. Secure with bolts if grounded. See photos 3-5.

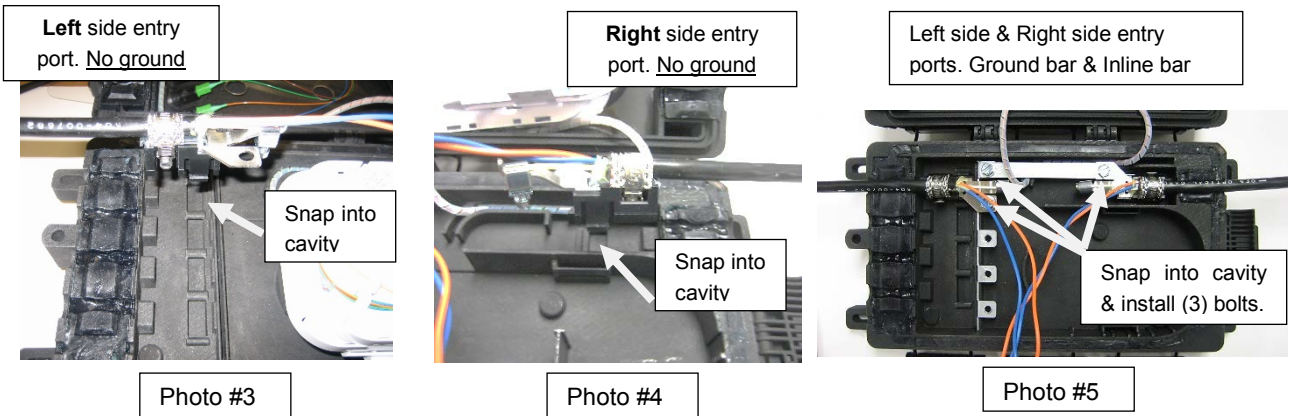

3.1.8 Store express buffer tube(s) as seen in photo 8. Store inline cable entering from right side first, then cable entering from left side. Tray stack may be removed for easier access to storage. See photos 6-8.

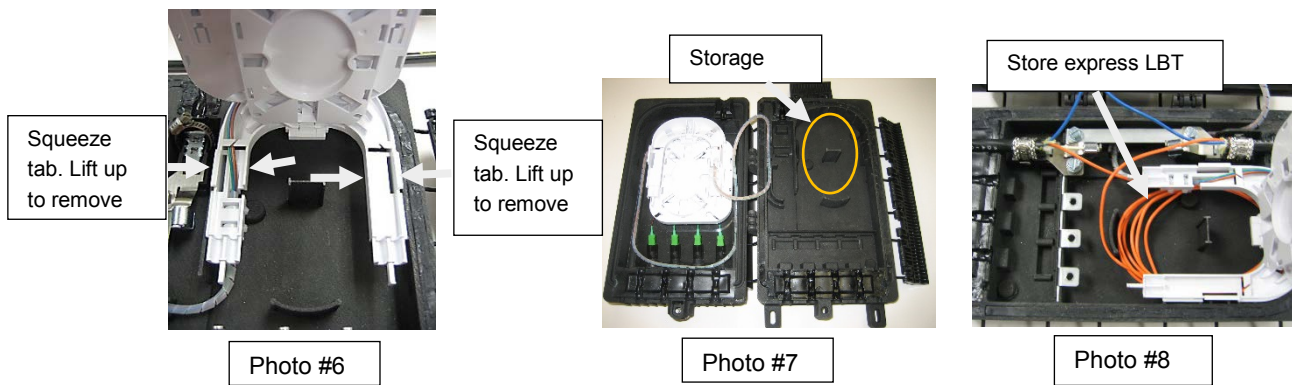

3.1.9 Create mid-span opening of LBT containing fiber to be spliced as follows: mark buffer tube 5" from the sheath opening on cable entering closure from the left. Mark buffer tube 10" from the sheath opening on the cable entering closure from the right. Remove 41" of buffer tube between the two marks. See Figure 2.

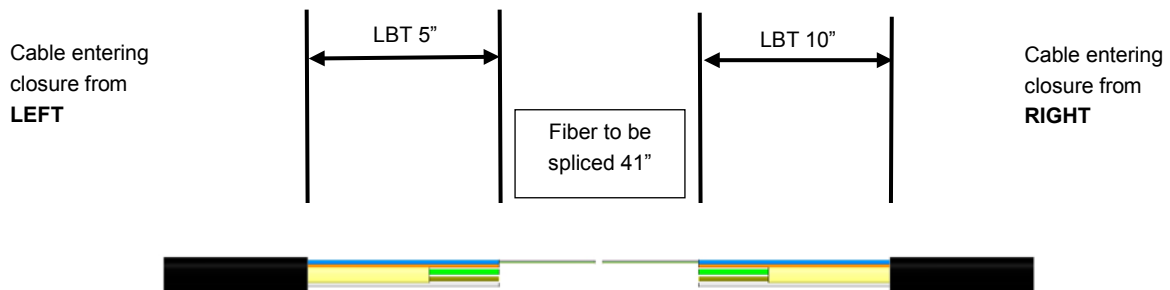

**Figure 2**

3.1.10 Cut fibers to be spliced 41" from the buffer tube opening from incoming signal side of cable

3.1.11 Proceed to **section 3.4** Fiber Routing and Splicing.

## 3.2 CABLE & EXTERNAL GROUNDING

3.2.1 For cable with shielding, remove a section of the outer sheath 180° around the cable by 1.0" in length measured from the end of the outer sheath in order to expose cable shielding. See photo 9.

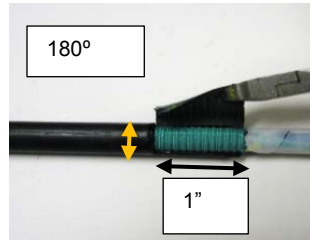

Photo #9



**NOTE:** Exposed shielding will be bonded to the cable retention bracket and ground bar.

3.2.2 For grounding, press ground bar into slot in closure. If using Inline configuration, install inline ground bar and secure with bolt. See photo 10.

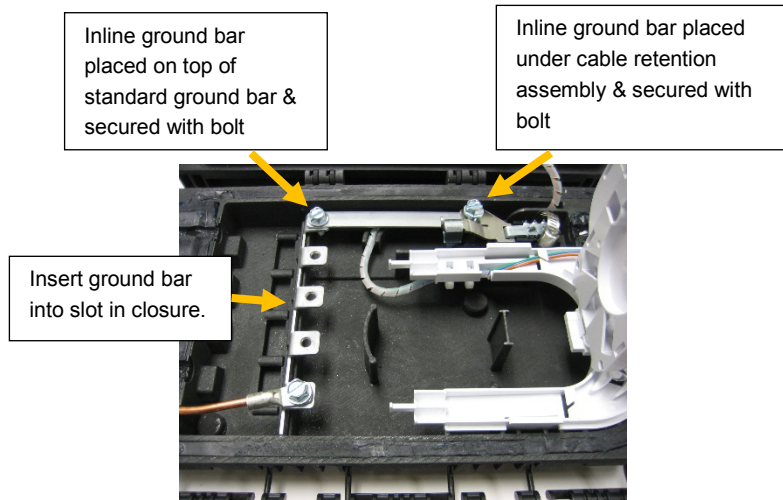
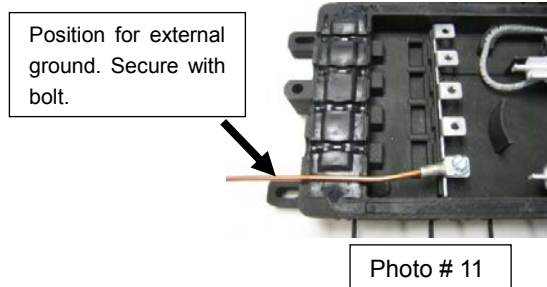

Photo # 10

3.2.3 External ground connection is to be placed in designated location. The ground wire is to be secured using the same bolt that is used to secure the cable retention assembly or secured with bolt. See photo 11.

▶ **Caution:** Do not use braided or stranded ground wire when installing a ground through a port on the Mini-OTE 300 closure. A solid ground wire is required to prevent a leak path and make a proper seal.



3.2.4 Proceed to **Section 3.3** to assemble cable retention hardware.

## 3.3 CABLE RETENTION

3.3.1 If LBT cable, remove any dummy buffer tubes by cutting at cable sheath opening. See photo 12.

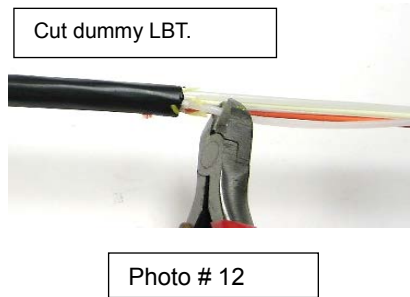

3.3.2 Open hose clamp on cable retention assembly. Place cable retention assembly around cable. If cable is shielded and to be grounded, orient the sheath opening, which exposes the shielding, toward the base of retention clamp. See photos 13-14.

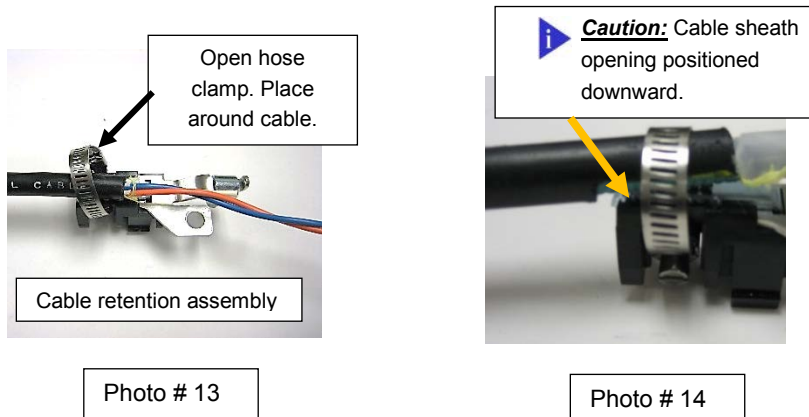

3.3.3 Insert strength member(s) into lug and hand tighten screw with the tool provided. See photo 15.

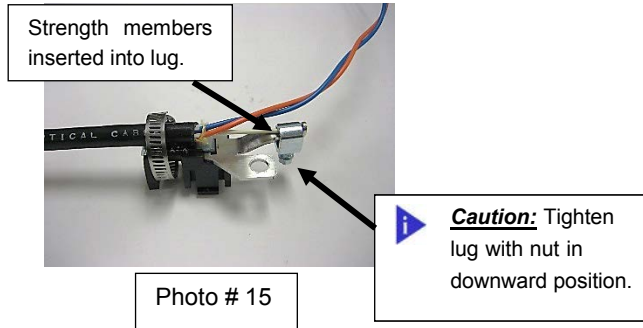

3.3.4 Cut perforated foil into 3 pieces (note orientation) and form over cable. If Flat Drop, wrap around drop. See photos 16-18.

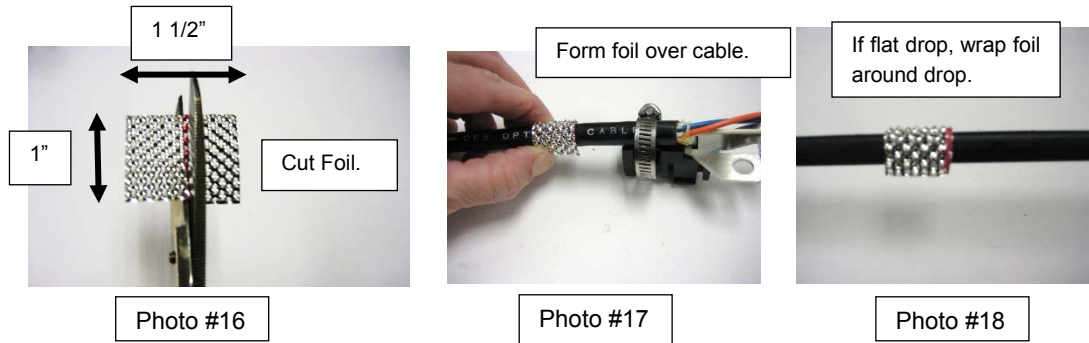

3.3.5 Place 1 pc of perforated foil between the hose clamp and outer sheath of cable. Tighten hose clamp being sure to keep the screw head positioned under the cable retention assembly in order to avoid interference when installing closure. See photos 19-20.



3.3.6 Return to Cable Preparation **Section 3.1.6.**



## 3.4 FIBER ORGANIZING/STORAGE, ROUTING AND SPLICING

3.4.1 INLINE EXPRESS (thru) configuration LBT Standard & Micro, Flat Drop with or without Trace wire

3.4.2 Route LBT to be spliced to routing tray. See photo 21.

 **Note:** Left side LBTs to be routed first. Right side LBTs to cross over LBTs from left side. Otherwise route buffer tube directly to routing tray.

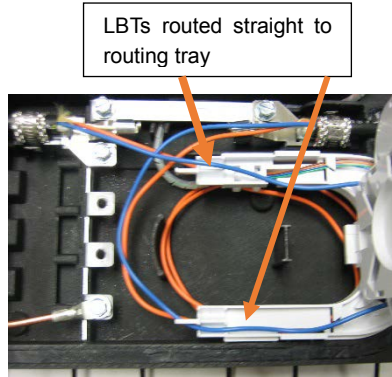

LBTs routed straight to routing tray

Photo # 21

3.4.3 Place appropriate grommet onto buffer tube. If more than one buffer tube, both may be installed into one grommet. Insert into routing tray, sliding grommet to align with retaining groove in routing tray. Secure with cable tie. See photos 22-26A.

Standard LBT



Photo #22

Micro LBT Grommet



Photo # 23

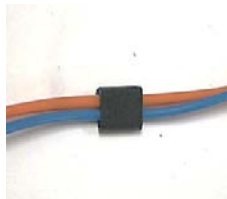

Photo # 24

Routing tray grommet slot

1" of LBT to remain beyond grommet

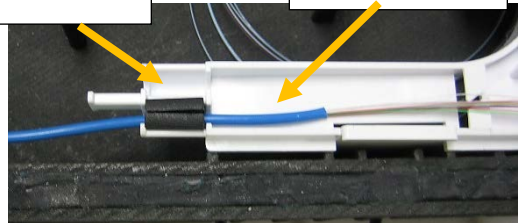

Photo # 25

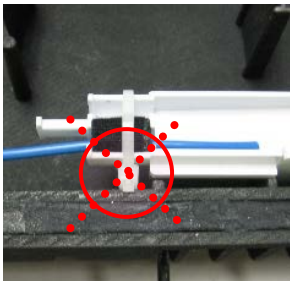



Photo # 26

 Secure with cable tie so that it is oriented as shown in photo # 26A

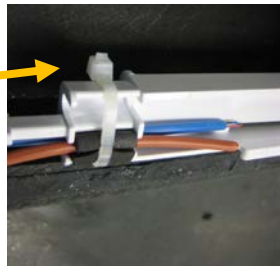

Photo # 26A

3.4.4 Repeat steps 3.4.2 to 3.4.3 with buffer tube coming from other end of cable.

3.3.5 Route express fibers and fibers cut “dead to field” to the Feed Thru tray. See photo 27.

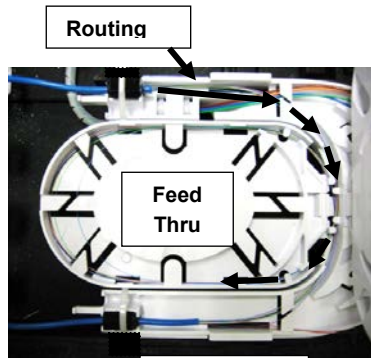

Photo # 27

3.4.6 Route fiber(s) to be spliced to top tray. See photos 28-30.

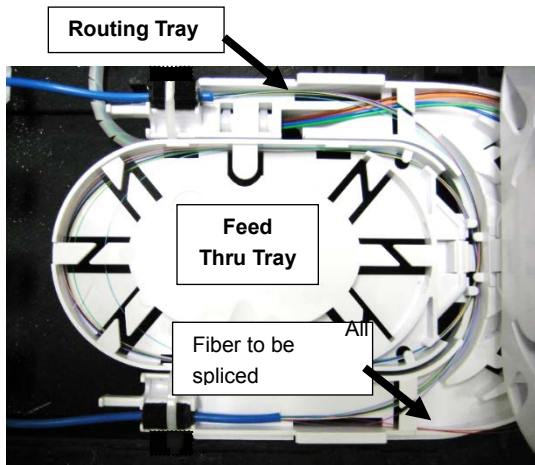

Photo # 28

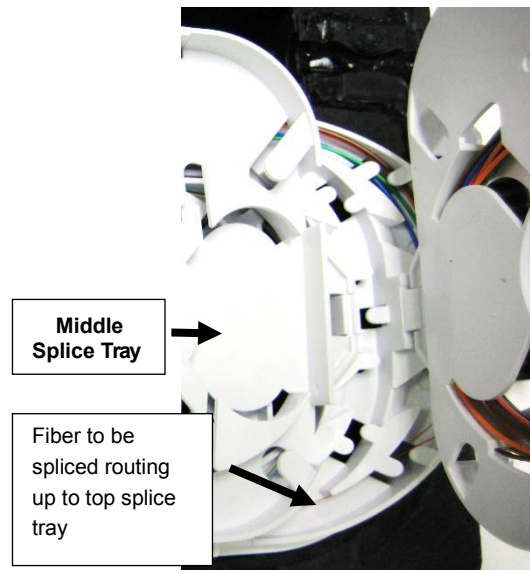

Photo # 29

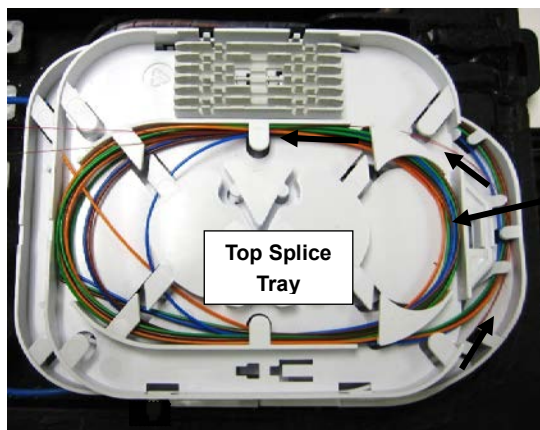

Photo # 30

Fiber routed to top splice tray

**Caution:** SMOUVS must be centered when placed in the holders.

3.4.7 Splice per standard practice. Replace dust cover on tray after splicing.

## 3.5 CLOSING / SECURING CLOSURE

3.5.1 Apply optional routing label inside lid or on tray cover.

3.5.2 Install port plugs into all unused ports, including ground port if no ground wire. See photo 31.

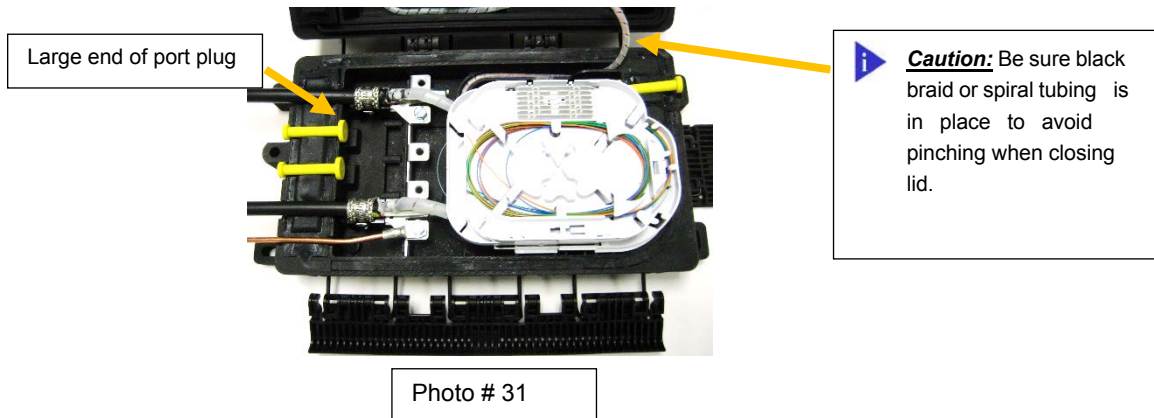

3.5.3 Close lid. Ensure all port plugs, ground wire (if present) and cables are properly aligned. Snap right side hinge, left side hinge, then top hinge. Hinges can be closed using screwdriver or by hand. See photos 32-34.



3.5.4 Tighten security bolt. See photo 35.

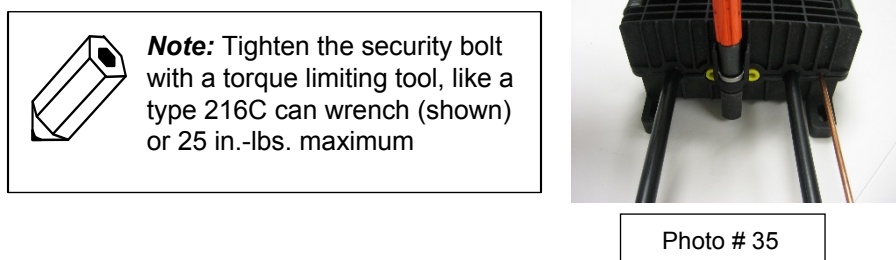



## 3.6 MOUNTING CLOSURE (PEDESTAL, STRAND & POLE MOUNT)

3.6.1 For pedestal mounting, assemble mounting bracket(s) to back of housing. Assemble to plate or rod.  
See photos 36 A-D



Photos 36 A-D

3.6.2 For strand mounting, assemble strand clamps or supplementary mounting brackets to back of housing. Assemble to line. See photos 36 E – F.

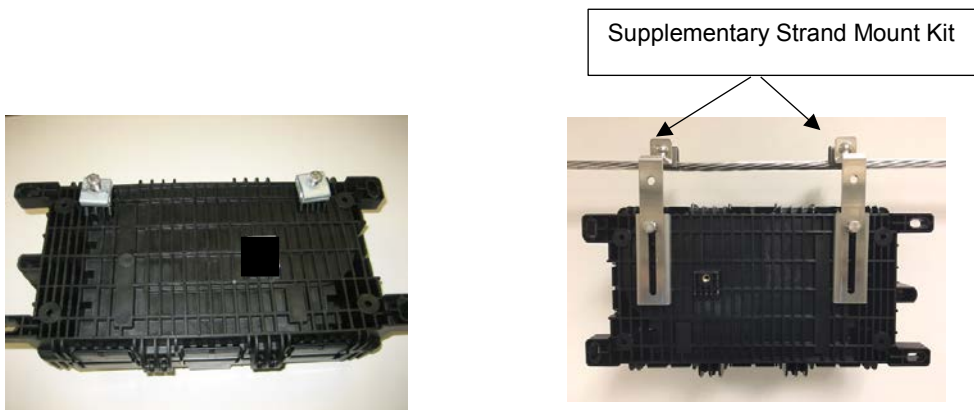

Photos 36 E- F

3.6.3 For pole mounting, assemble supplementary mounting brackets to back of housing and assemble to pole. See photo 37.

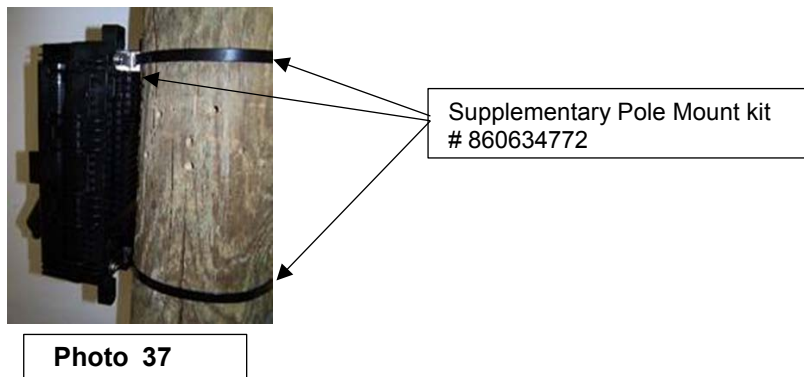



# Chapter 4. Butt Express – LBT Standard and Micro, Flat drop with/without trace wire

## 4.0 CABLE PREPARATION

### 4.1 Butt Express (Thru) Configuration

4.1.1 Preparation of Loose Buffer Tube Standard or Micro and Flat Drop with or without trace wire. Prepare mid-span opening: remove 56" of outer sheath. See Figure 3.

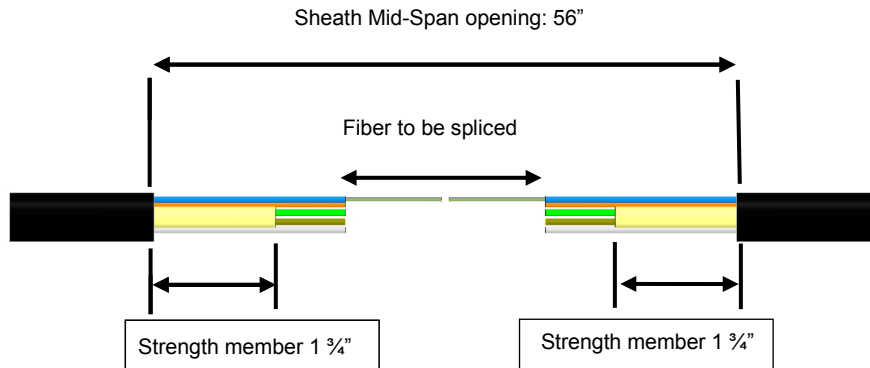

Figure 3

4.1.2 Cut strength member(s) 1 3/4" from end of sheath openings. See Figure 3. If Flat Drop has trace wire, cleanly cut away 4" of trace wire from end of sheath opening. See photos 38-39.

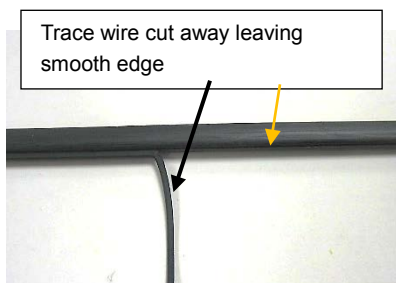

Photo # 38

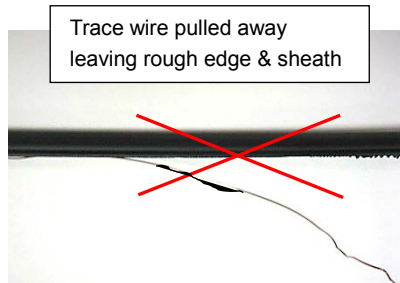

Photo # 39

4.1.3 If cable is shielded and to be grounded proceed to **Section 4.2** Cable and External Grounding.

4.1.4 Proceed to **Section 4.3** to assemble cable retention hardware to each cable end opening.

4.1.5 Separate buffer tube (s) containing fibers to be spliced from LBT bundle.

4.1.6 Snap cable retention assemblies into the appropriate locations. See photos 40-42. Secure with bolt if grounded.

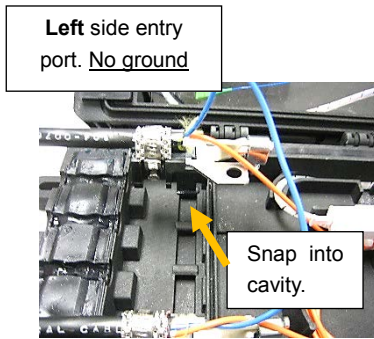

Photo #40

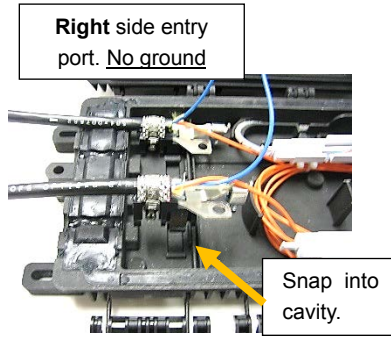

Photo #41

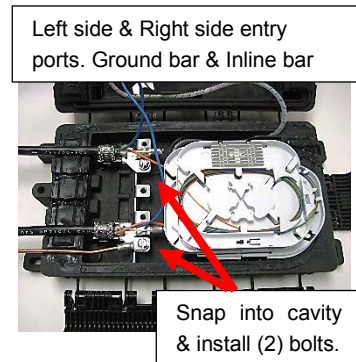

Photo #42

4.1.7 Store express buffer tube(s) as seen in photo #45. Tray stack may be removed for easier access to storage. See photos 43-45.

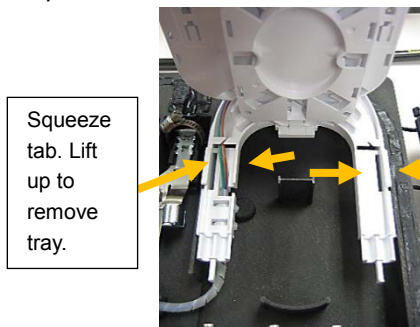
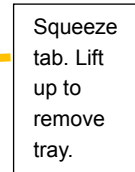

Photo #43



Storage



Photo #44

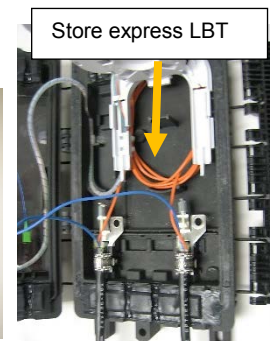

Photo #45

4.1.8 Create mid-span opening of LBT containing fiber to be spliced as follows: mark buffer tube 5" from the each end of sheath opening. Remove 46" of buffer tube between the two marks. See Figure 4.

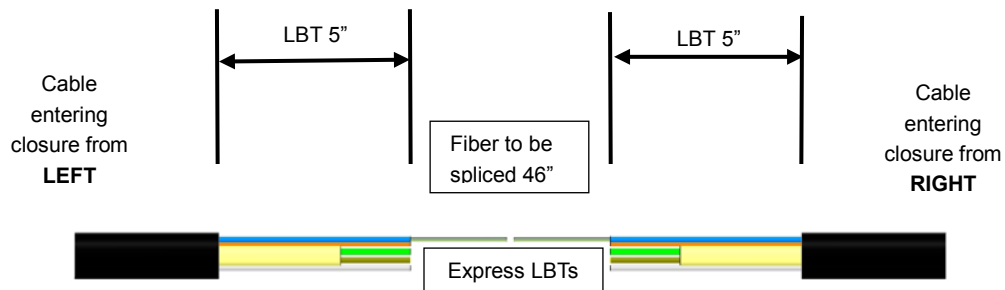

Figure 4

4.1.9 Cut fibers to be spliced 46" from the buffer tube opening, on the incoming signal side.

4.1.10 Proceed to **Section 4.4** Fiber Routing and Splicing.

## 4.2 CABLE & EXTERNAL GROUNDING

4.2.1 For cable with shielding, remove a section of the outer sheath 180° around the cable by 1.0" in length measured from the end of the outer sheath in order to expose cable shielding. See photo 46.

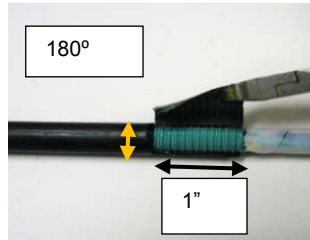

Photo #46



**NOTE:** Exposed shielding will be bonded to the cable retention bracket and ground bar.

4.2.2 For grounding, press ground bar into slot in closure. If using Inline configuration, install inline ground bar and secure with bolt. See photo 47.

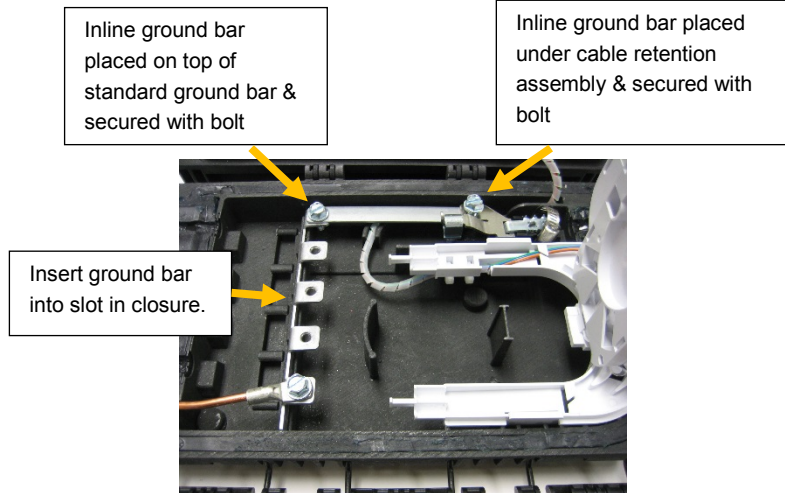

Photo # 47

4.2.3 External ground connection is to be placed in designated location. The ground wire is to be secured using the same bolt that is used to secure the cable retention assembly or secured with bolt. See photo 48.

**Caution:** Do not use braided or stranded ground wire when installing a ground through a port on the Mini-OTE 300 closure. A solid ground wire is required to prevent a leak path and make a proper seal.

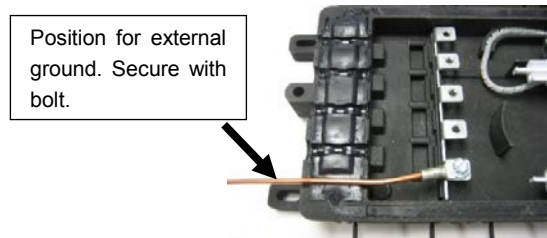

Photo # 48

4.2.4 Proceed to **Section 4.3** to assemble cable retention hardware.

## 4.3 CABLE RETENTION

4.3.1 If LBT cable, remove any dummy buffer tubes by cutting at cable sheath opening. See photo 49.

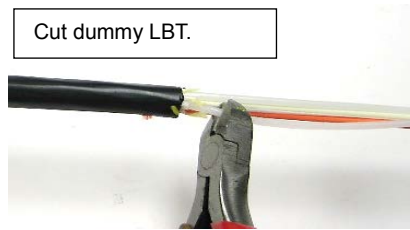

Photo # 49

4.3.2 Open hose clamp on cable retention assembly. Place cable retention assembly around cable. If cable is shielded and to be grounded, orient the sheath opening, which exposes the shielding, toward the base of retention clamp. See photos 50-51.

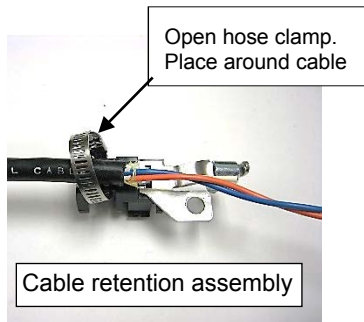

Photo # 50

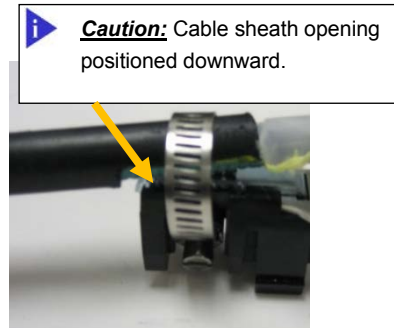

Photo # 51

4.3.3 Insert strength member(s) into lug and hand tighten screw with the tool provided. See photo 52.

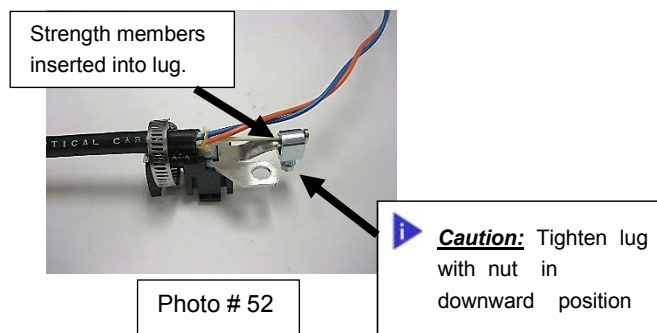

Photo # 52

4.3.4 Cut perforated foil into 3 pieces (note orientation) and form over cable. If Flat Drop, wrap around drop. See photos 53-55.

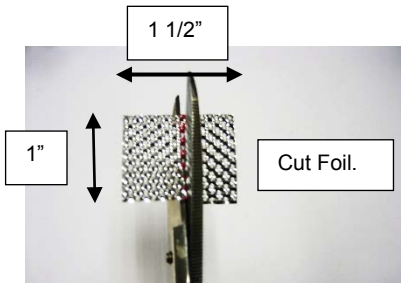

Photo #53

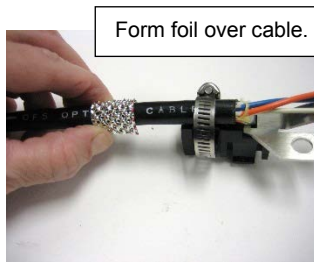

Photo #54



Photo #55

4.3.5 Place 1 pc of perforated foil between the hose clamp and outer sheath of cable. Tighten hose clamp being sure to keep the screw head positioned under the cable retention assembly in order to avoid interference when installing closure. See photos 56-57.

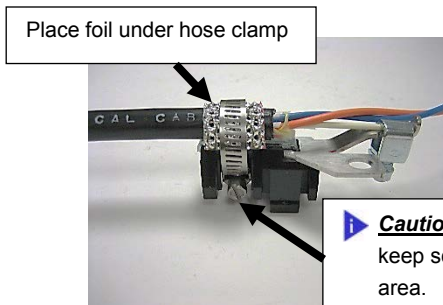

Photo #56

**Caution:** Tighten screw, keep screw in contained area.

**Caution:** If shielded, keep cable positioned as shown, while tightening hose clamp.



Photo #57

4.3.6 Return to Cable Preparation **Section 4.1.6.**

### 4.4 FIBER ORGANIZING/STORAGE, ROUTING AND SPLICING

4.4.1 BUTT EXPRESS (thru) configuration: LBT Standard & Micro, Flat Drop with or without Trace wire

4.4.2 Route LBT to be splice to routing tray. See photo 58.

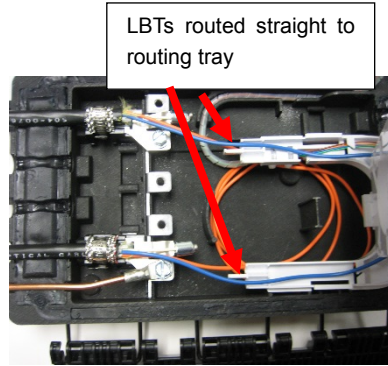

LBTs routed straight to routing tray

Photo # 58

4.4.3 Place appropriate grommet onto buffer tube. If more than one buffer tube, both may be installed into one grommet. Insert into routing tray, sliding grommet to align with retaining groove in routing tray. Secure with cable tie. See photos 59-63A.

Standard LBT

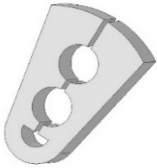

Photo# 59

Micro LBT Grommet



Photo # 60

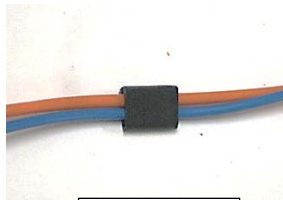

Photo # 61

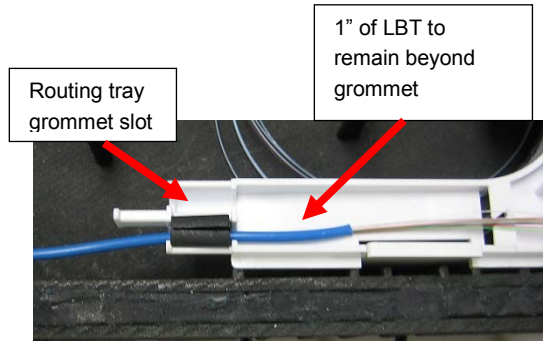

Photo #62

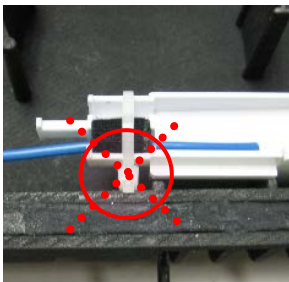

Photo # 63

**Caution:** Secure with cable tie so that it is oriented as shown in photo # 63A

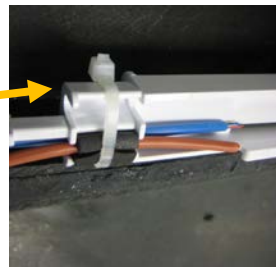

Photo # 63A

4.4.4 Repeat steps 4.4.2 – 4.4.3 with buffer tube coming from other end of cable.

4.4.5 Route express fibers and fibers cut “dead to field” to the Feed Thru tray. See photo 64.

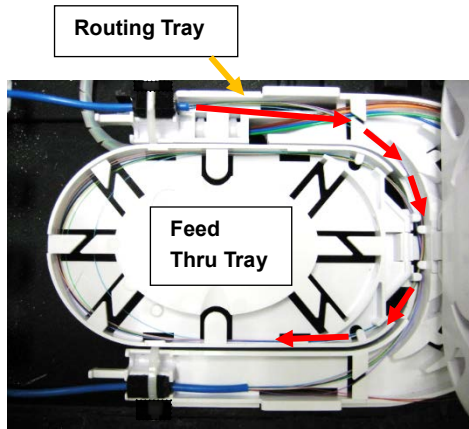

Photo # 64

4.4.6 Route fiber(s) to be spliced to top splicing tray. See photos 65-67.

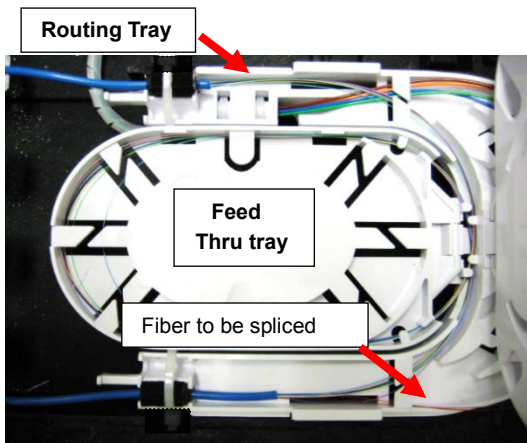

Photo # 65

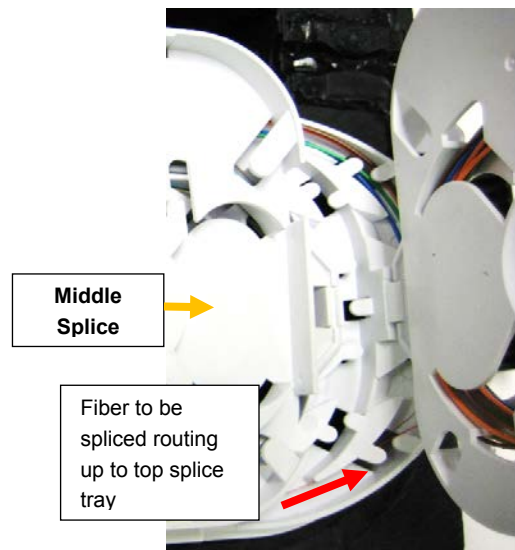

Photo # 66

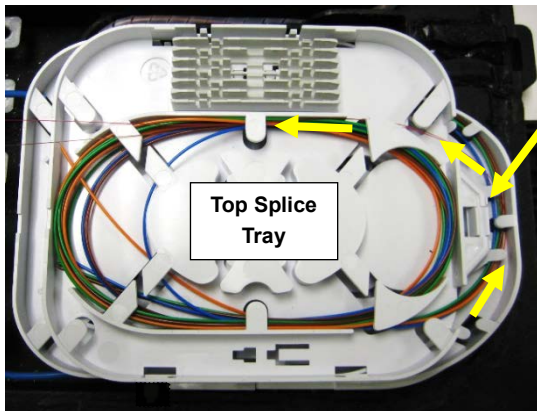

Photo # 67

Fiber routed to top splice tray

**Caution:** SMOUVS must be centered when placed in the holders.

4.4.7 Splice per standard practice. Replace dust cover on tray after splicing.



## 4.5 CLOSING / SECURING CLOSURE

4.5.1 Apply optional routing label inside lid or on tray cover.

4.5.2 Install port plugs into all unused ports. See photo 68.

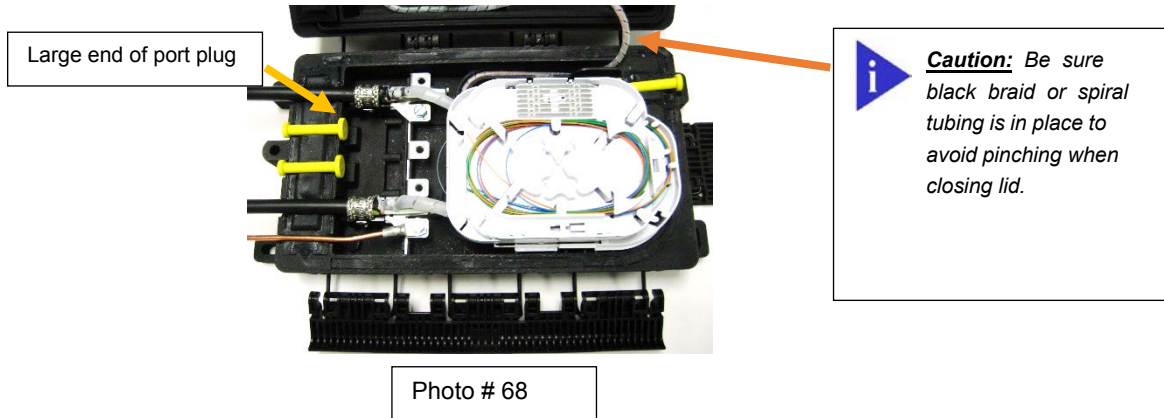

4.5.3 Close lid. Ensure all port plugs, including ground plug if no ground wire (if present) and cables are properly aligned. Snap right side hinge, left side hinge, and then top hinge. Hinges can be closed using **screwdriver** or **by hand**. See photos 69-71.

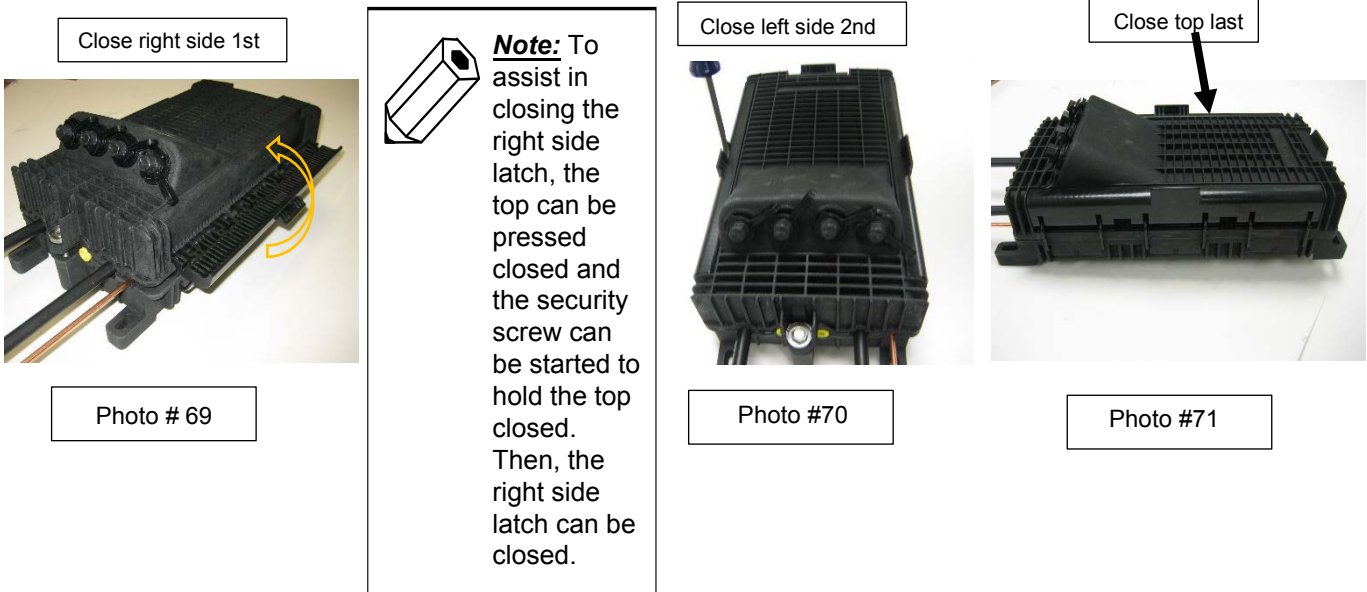

4.5.4 Tighten security bolt. See photo 72.

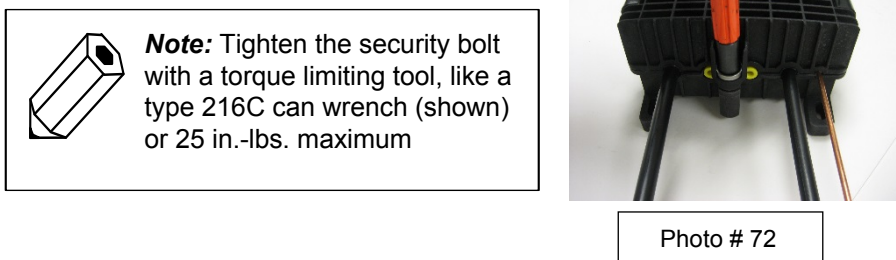

## 4.6 MOUNTING CLOSURE (PEDESTAL, STRAND & POLE MOUNT)

4.6.1 For pedestal mounting, assemble mounting bracket(s) to back of housing. Assemble to plate or rod.  
See photos 36 A-D

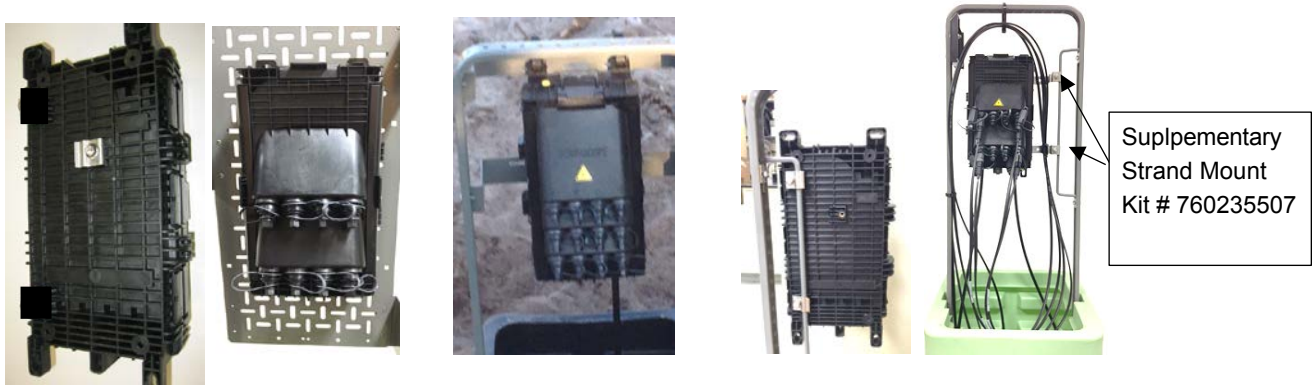

Photos 36 A-D

4.6.2 For strand mounting, assemble strand clamps or supplementary mounting brackets to back of housing.  
Assemble to line. See photos 36 E – F.

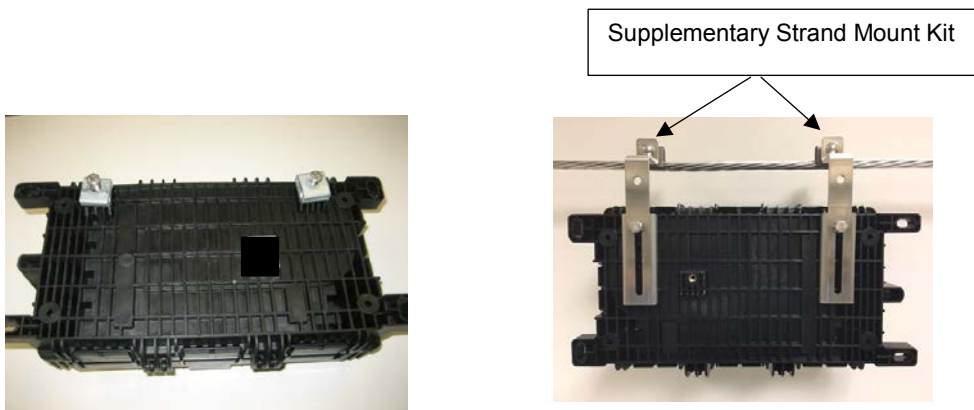

Photos 36 E- F

4.6.3 For pole mounting, assemble supplementary mounting brackets to back of housing and assemble to pole.  
See photo 37.

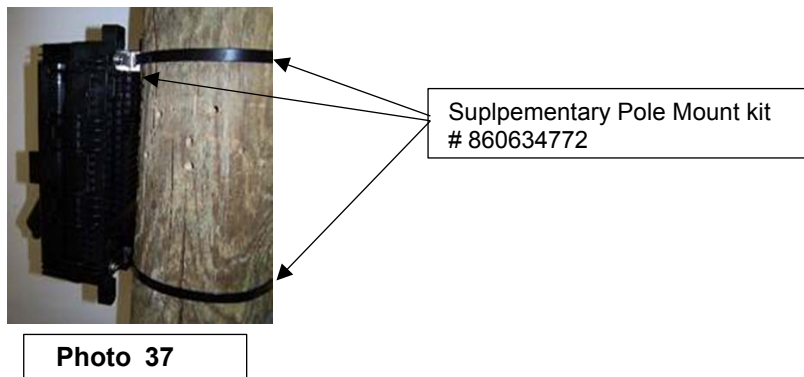

Photo 37

# Chapter 5. Inline Stub – LBT Standard and Micro, Flat Drop with/without trace wire

## 5.0 CABLE PREPARATION

### 5.1 Inline Stub (Cable End) Configuration

5.1.1 Remove 55" of outer sheath from end of cable. Figure 5.

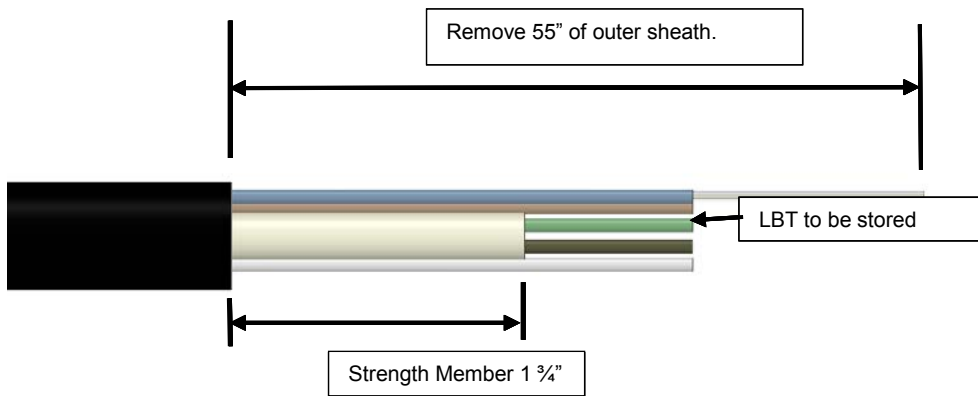
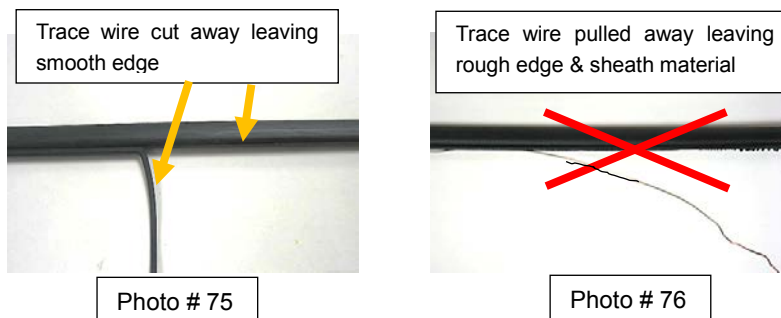

Figure 5

5.1.2 Cut strength member(s) 1 3/4" from end of sheath openings. Figure 5. If flat drop has a trace wire, cleanly cut away 4" of wire from end of sheath opening. See photo 75-76.



5.1.3 If is cable shielded and to be grounded proceed to **Section 5.2** Cable and External Grounding.

5.1.4 Proceed to **Section 5.3** to assemble cable retention hardware to each cable end opening.

5.1.5 Separate buffer tube (s) containing fibers to be spliced from LBT bundle.

5.1.6 Snap cable retention assemblies into the appropriate locations. Secure with bolt if grounded.  
See photos 77-79.

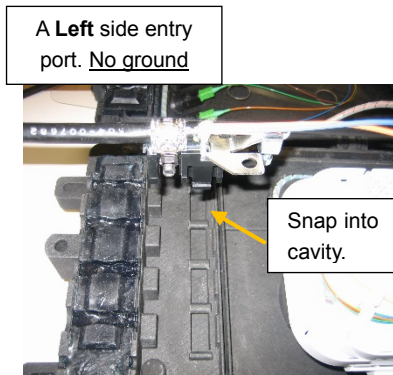

Photo #77

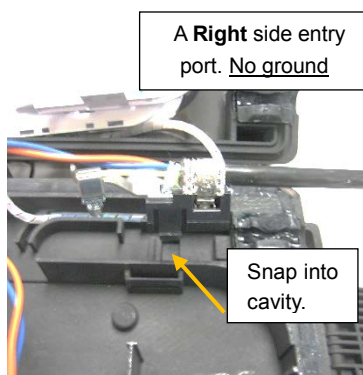

Photo #78

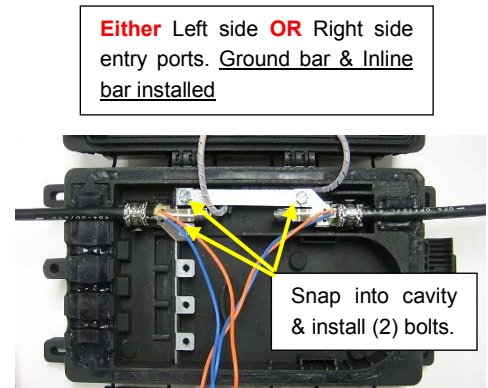

Photo #79

5.1.7 If all fibers in a LBT are not to be spliced, route to storage area. Tray stack may be removed for easier access to storage. See photos 80-83.

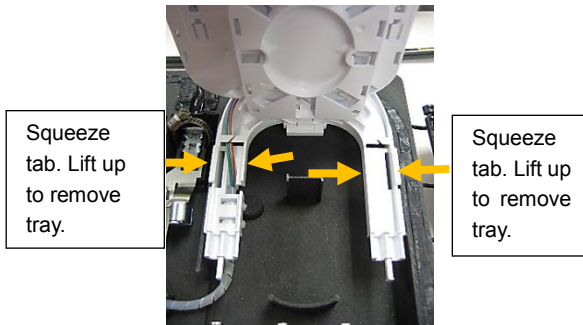

Photo #80

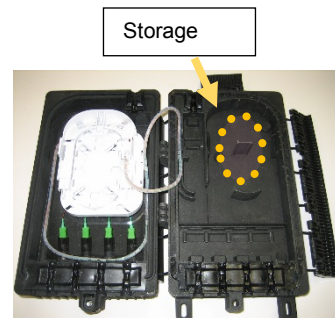

Photo #81

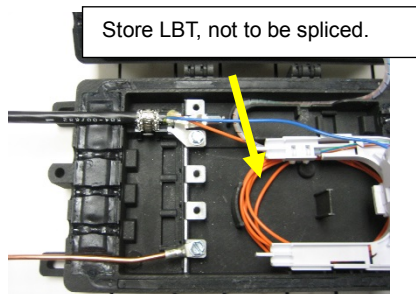

Photo #82



Photo #83

5.1.8 If cable enters closure from the right, mark buffer tube **23"** from sheath opening, ring cut and remove tubing. See Figure 6.

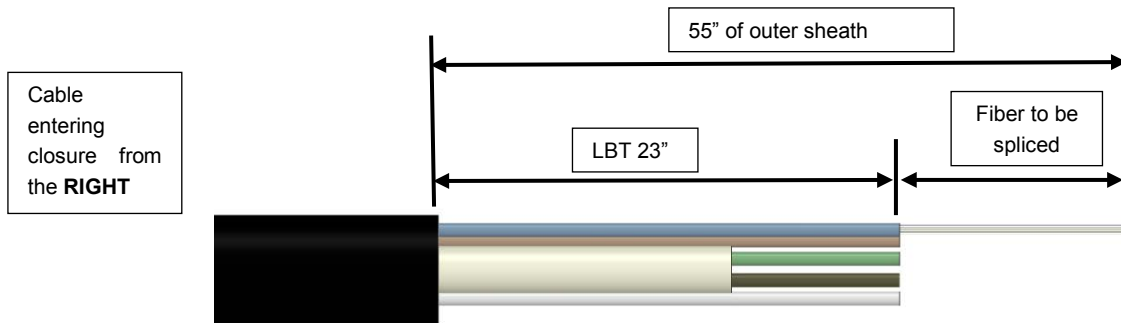

Figure 6

5.1.9 If cable enters closure from the left, mark buffer tube **17"** from sheath opening, ring cut and remove tubing. See Figure 7.

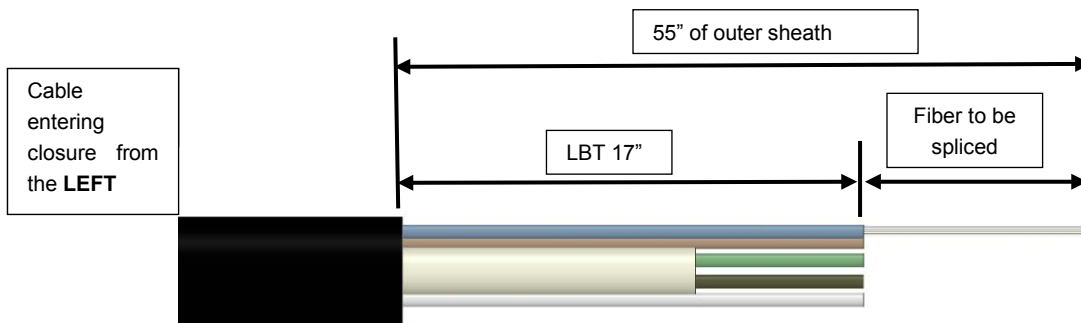

Figure 7

5.1.10 Proceed to **Section 5.4** Fiber Routing and Splicing.

## 5.2 CABLE & EXTERNAL GROUNDING

5.2.1 For cable with shielding, remove a section of the outer sheath 180° around the cable by 1.0" in length measured from the end of the outer sheath in order to expose cable shielding. See photo 84.

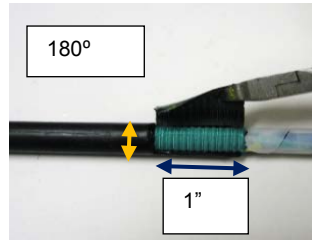

Photo #84



**NOTE:** Exposed shielding will be bonded to the cable retention bracket and ground bar.

5.2.2 For grounding, press ground bar into slot in closure. If using Inline configuration, install inline ground bar and secure with bolt. See photo 85.

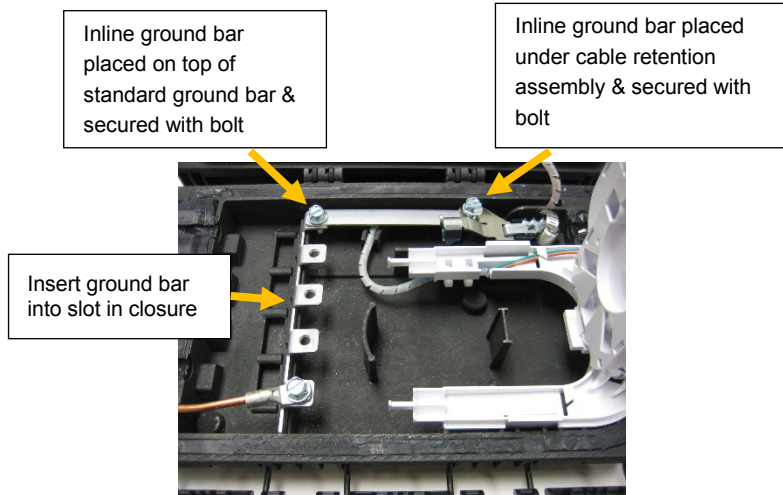

Photo # 85

5.2.3 External ground connection is to be placed in designated location. The ground wire is to be secured using the same bolt that is used to secure the cable retention assembly or secured with bolt. See photo 86.

▶ **Caution:** Do not use braided or stranded ground wire when installing a ground through a port on the Mini-OTE 300 closure. A solid ground wire is required to prevent a leak path and make a proper seal.

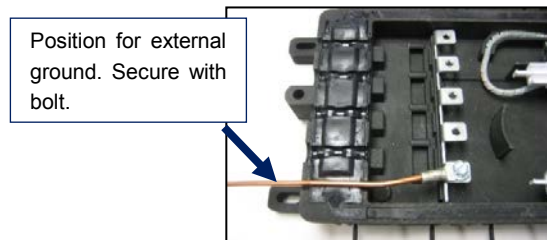

Photo # 86

## 5.3 CABLE RETENTION

5.3.1 If LBT cable, remove any dummy buffer tubes by cutting at cable sheath opening. See photo 87.

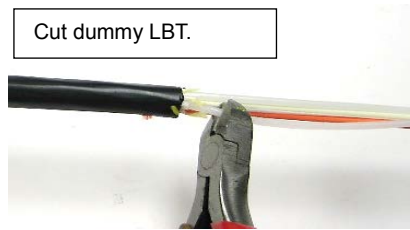

Photo # 87

5.3.2 Open hose clamp on cable retention assembly. Place cable retention assembly around cable. If cable is shielded and to be grounded, orient the sheath opening, which exposes the shielding, toward the base of retention clamp. See photos 88-89.

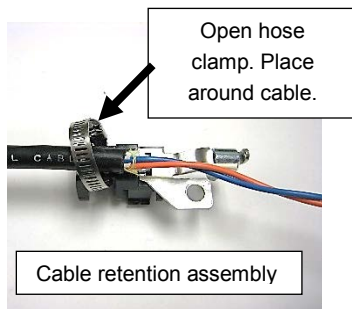

Photo # 88

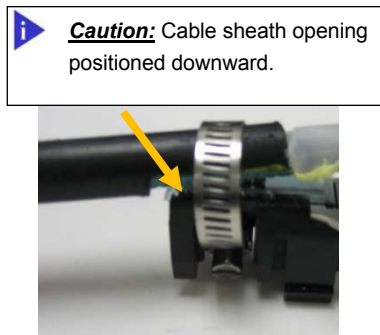

Photo # 89

5.3.3 Insert strength member(s) into lug and hand tighten screw with the tool provided. See photo 90.

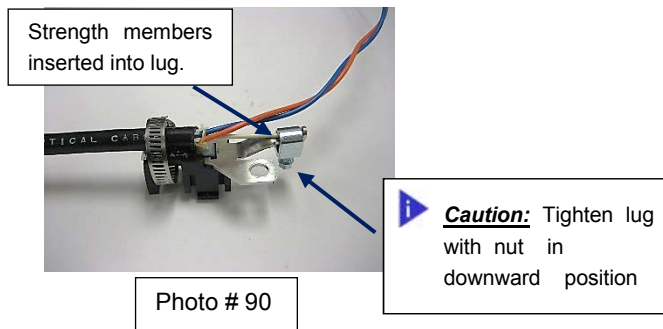
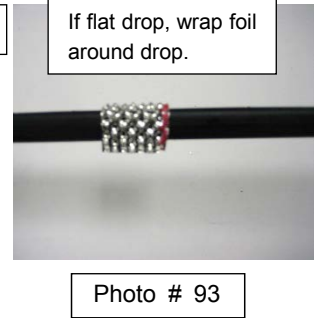
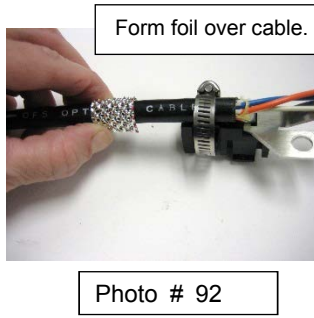
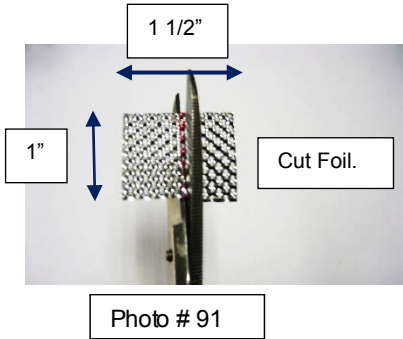
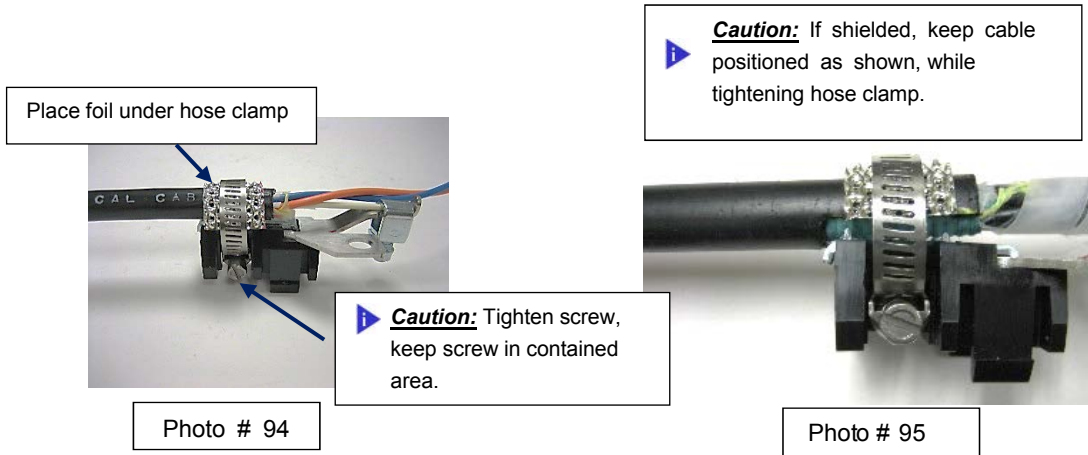

Photo # 90

5.3.4 Cut perforated foil into 3 pieces (note orientation) and form over cable. If Flat Drop, wrap around drop. See photos 91-93.



5.3.5 Place 1 pc of perforated foil between the hose clamp and outer sheath of cable. Tighten hose clamp being sure to keep the screw head positioned under the cable retention assembly in order to avoid interference when installing closure. See photos 94-95.



5.3.6 Return to Cable Preparation **Section 5.1.5.**



## 5.4 FIBER ORGANIZING/STORAGE, ROUTING AND SPLICING

5.4.1 Store one loop of buffer tube and proceed to routing tray. See photos 96-97.

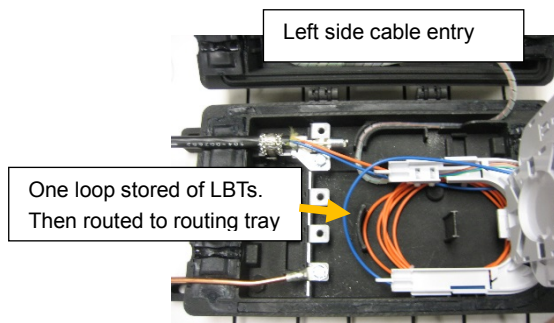

Photo # 96

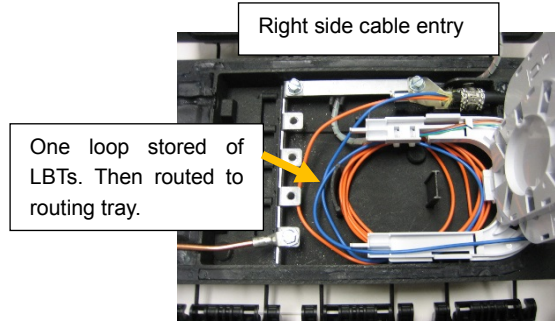

Photo # 97

5.4.2 Place appropriate grommet onto buffer tube. If more than one buffer tube, both may be installed into one grommet. Insert into routing tray sliding grommet to align with retaining groove in routing tray. Secure with cable tie. See photos 98-102A.

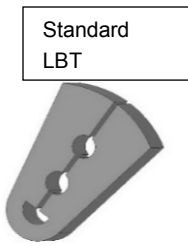

Photo #98

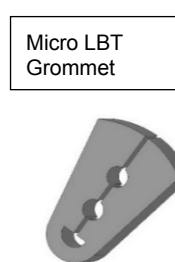

Photo #99



Photo #100

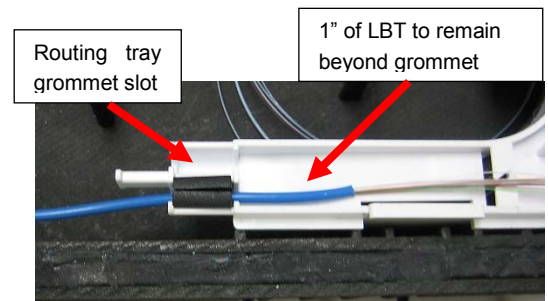

Photo # 101

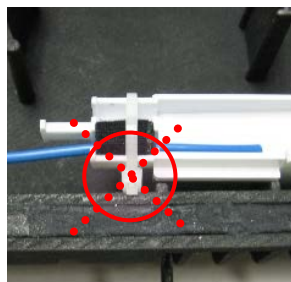

Photo # 102

**Caution:** Secure with cable tie so that it is oriented as shown in photo # 102A

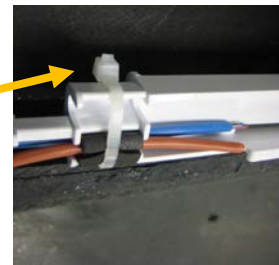

Photo # 102A

5.4.3 Route fiber(s) not to be spliced to Feed Thru tray. See photo 103.

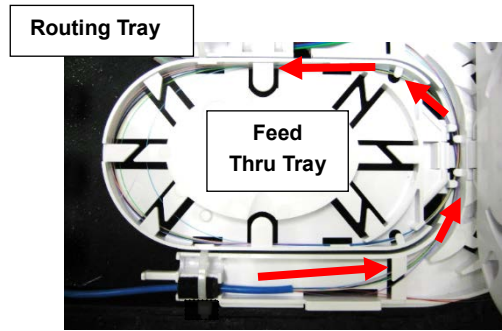

Photo # 103

5.4.4 Route fiber(s) to be spliced to top splicing tray. See photos 104-106.

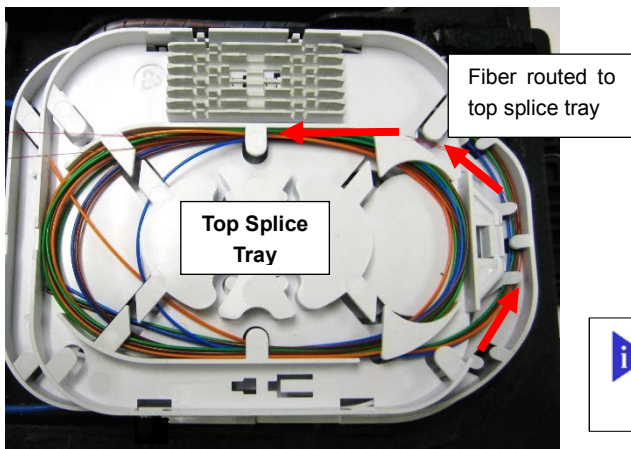
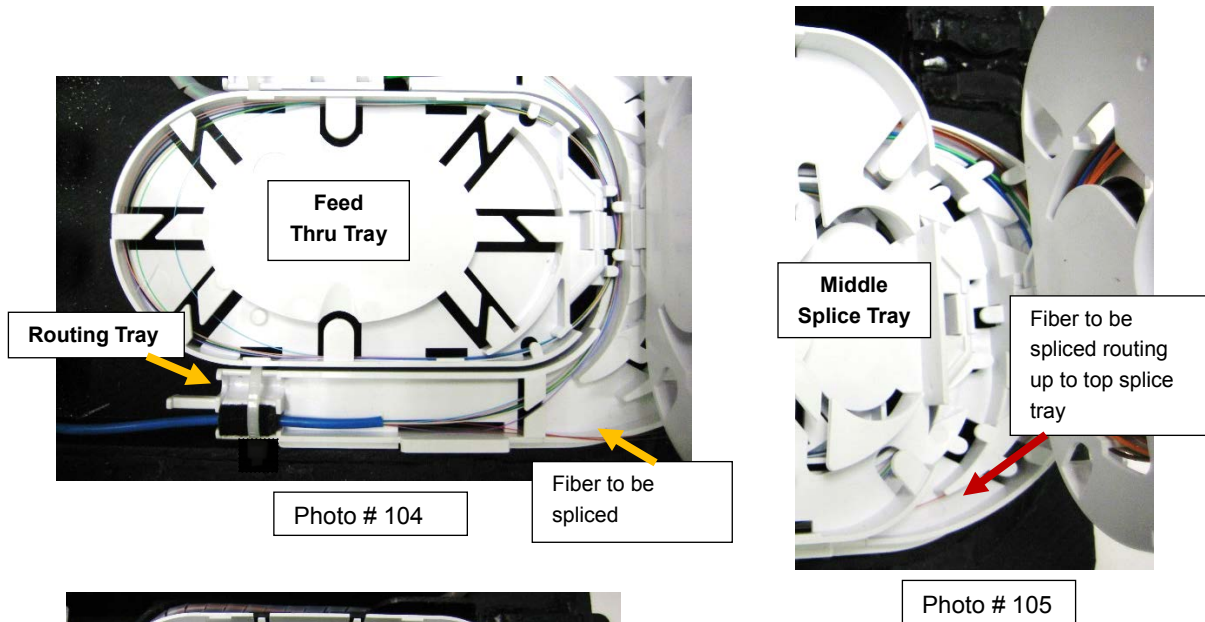



Photo # 106

 Caution: SMOUVS must be centered when placed in the holders.

5.4.5 Splice per standard practice. Replace dust cover on tray after splicing.

## 5.5 CLOSING / SECURING CLOSURE

5.5.1 Apply optional routing label inside lid or on tray cover.

5.5.2 Install port plugs into all unused ports including ground port if no ground wire. See photo 107.

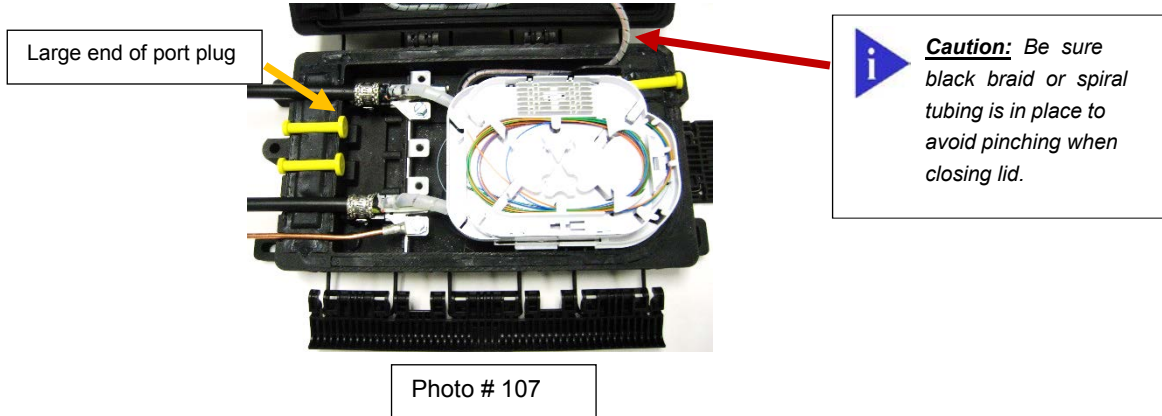

5.5.3 Close lid. Ensure all port plugs, ground wire (if present) and cables are properly aligned.

Snap right side hinge, left side hinge, and then top hinge. Hinges can be closed using screwdriver or by hand. See photos 108-110.

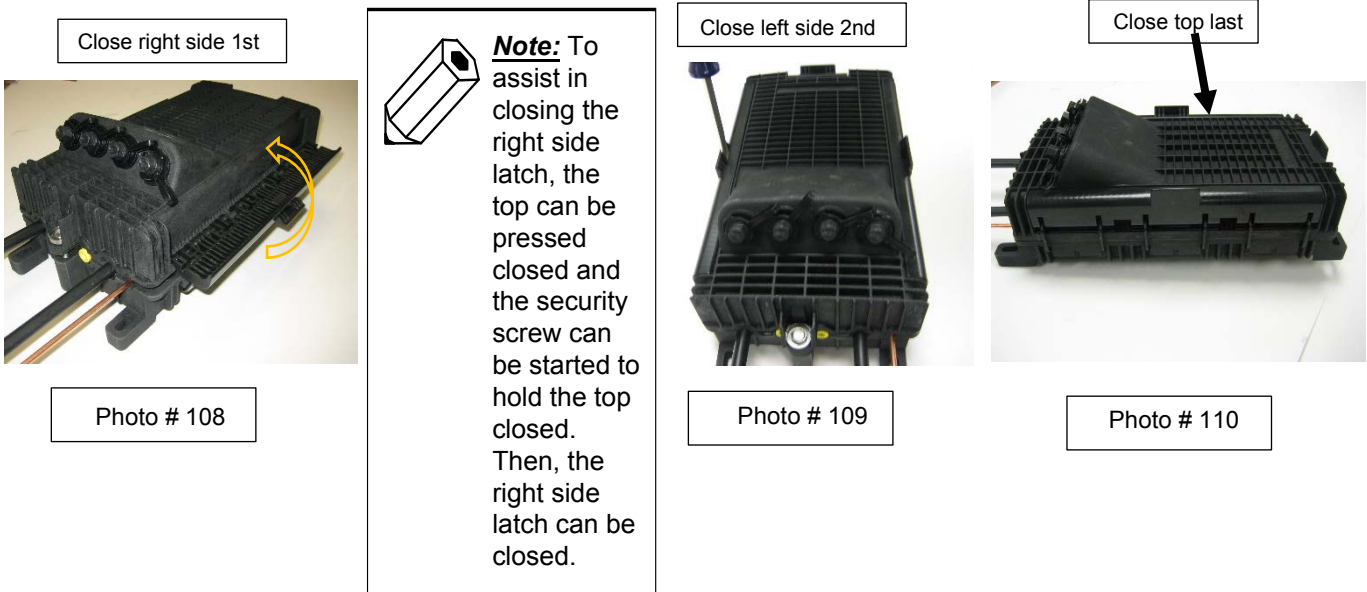

5.5.4 Tighten security bolt. See photo 35.

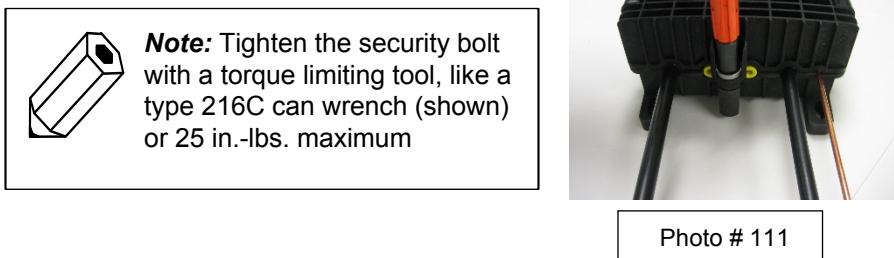

## 5.6 MOUNTING CLOSURE (PEDESTAL, STRAND & POLE MOUNT)

5.6.1 For pedestal mounting, assemble mounting bracket(s) to back of housing. Assemble to plate or rod.  
See photos 36 A-D

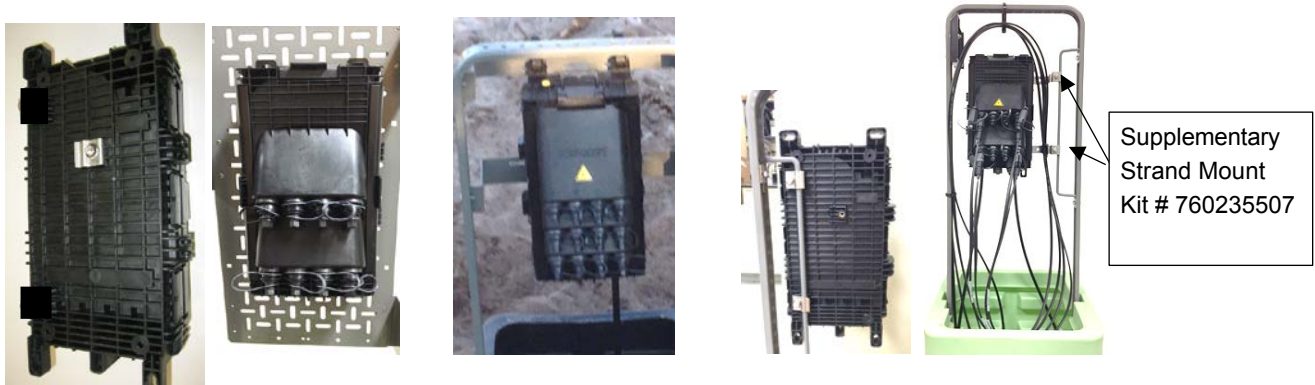

Photos 36 A-D

5.6.2 For strand mounting, assemble strand clamps or supplementary mounting brackets to back of housing. Assemble to line. See photos 36 E – F.

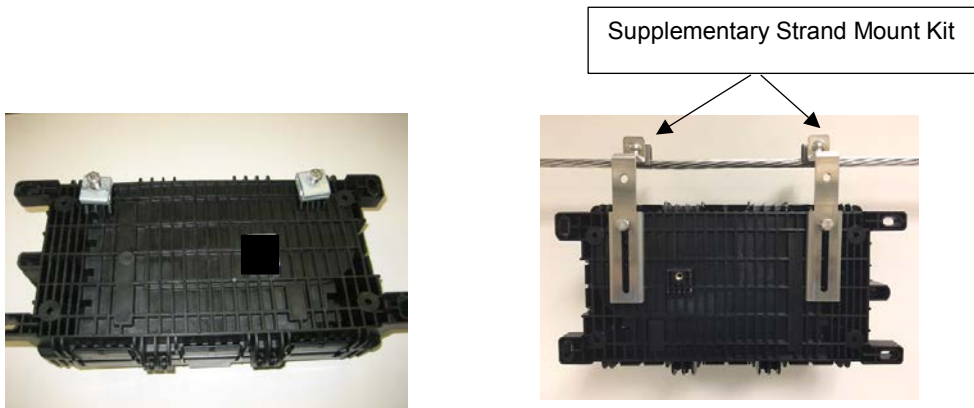

Photos 36 E- F

5.6.3 For pole mounting, assemble supplementary mounting brackets to back of housing and assemble to pole. See photo 37.

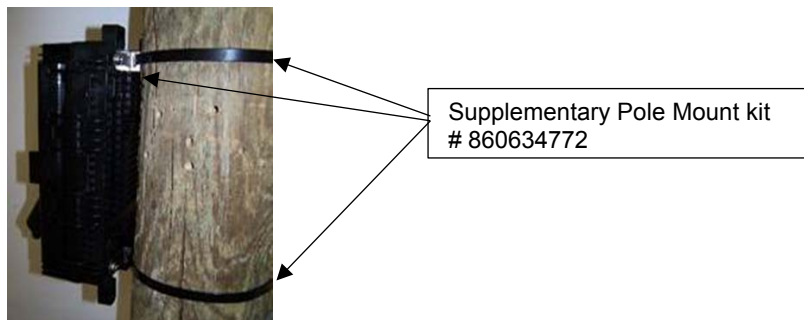

Photo 37

# Chapter 6. Butt Stub – LBT Standard and Micro, Flat Drop with/without trace wire

## 6.0 CABLE PREPARATION

### 6.1 Butt Stub (Cable End) Configuration

6.1.1 Remove 55" of outer sheath from end of cable. See Figure 8.

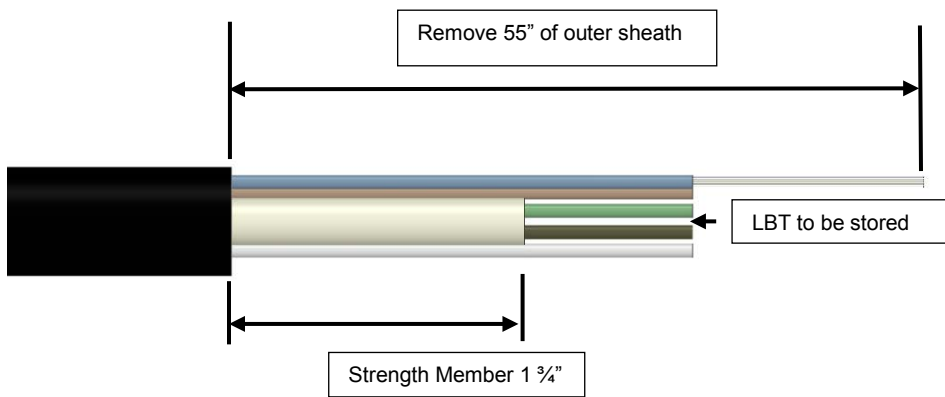

Figure 8

6.1.2 Cut strength member(s) 1 3/4" from end of sheath openings. See Figure 8. If Flat Drop has a trace wire, cleanly cut away 4" of wire from end of sheath opening. See photos 114-115.

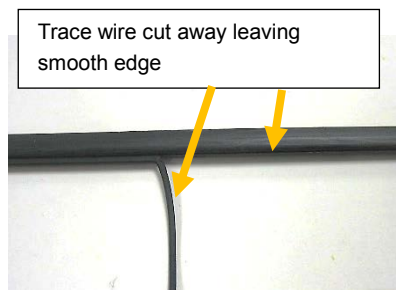

Photo # 114

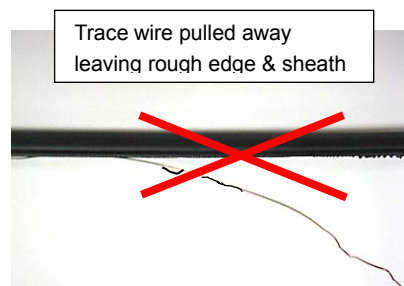

Photo # 115

6.1.3 If cable is shielded and to be grounded proceed to **Section 6.2** Cable and External Grounding.

6.1.4 Proceed to **Section 6.3** to assemble cable retention hardware to each cable end opening.

6.1.5 Separate buffer tube (s) containing fibers to be spliced from LBT bundle.

6.1.6 Snap cable retention assembly(s) into the appropriate locations. Secure with bolt if grounded. See photos 116 – 117.

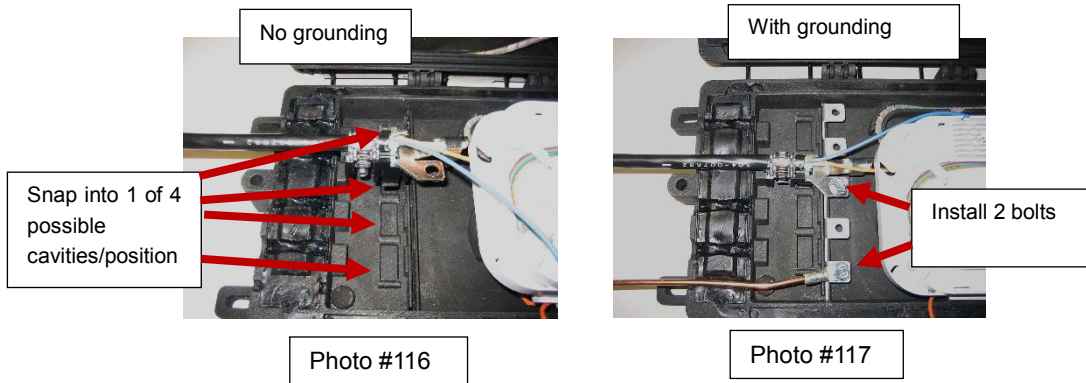

6.1.7 If all fibers in a LBT are not to be spliced, route LBT to storage area. Tray stack may be removed for easier access to storage. See photos 63-65.

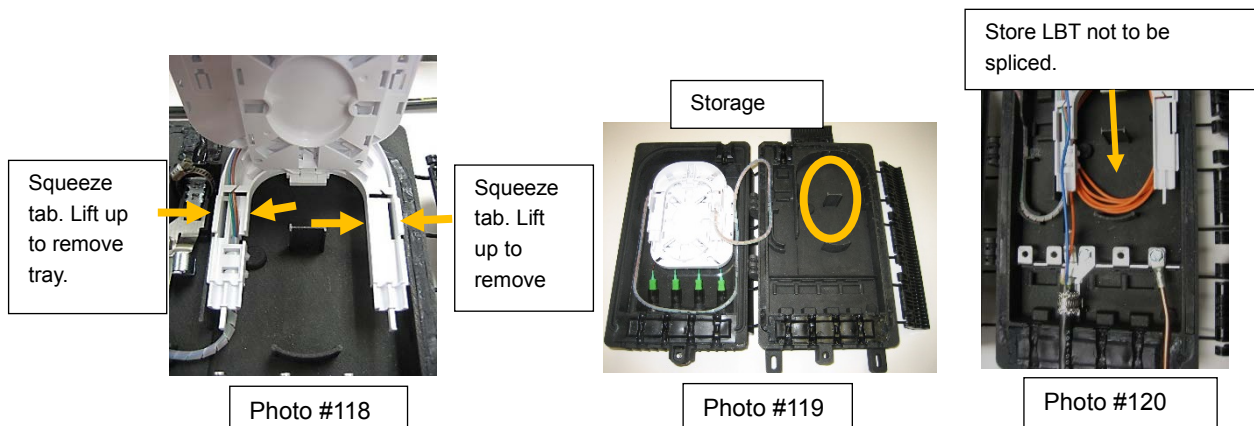

6.1.8 Mark buffer tube 17" from sheath opening, ring cut and remove tubing. See Figure 9.

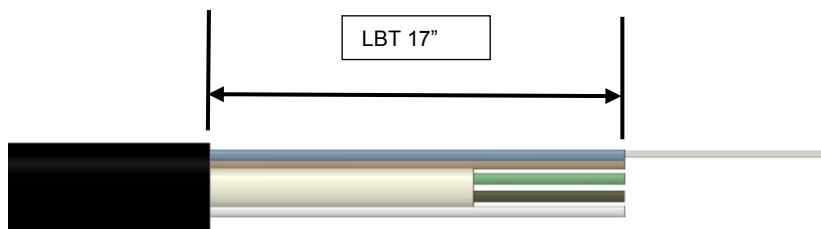

Figure 9

6.1.9 Proceed to **Section 6.4** Fiber Routing and Splicing

## 6.2 CABLE & EXTERNAL GROUNDING

6.2.1 For cable with shielding, remove a section of the outer sheath 180° around the cable by 1.0" in length measured from the end of the outer sheath in order to expose cable shielding. See photo 121.

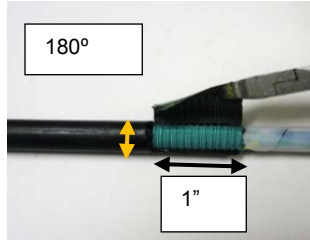

Photo #121



**NOTE:** Exposed shielding will be bonded to the cable retention bracket and ground bar.

6.2.2 For grounding, press ground bar into slot in closure. If using Inline configuration, install inline ground bar and secure with bolt. See photo 122.

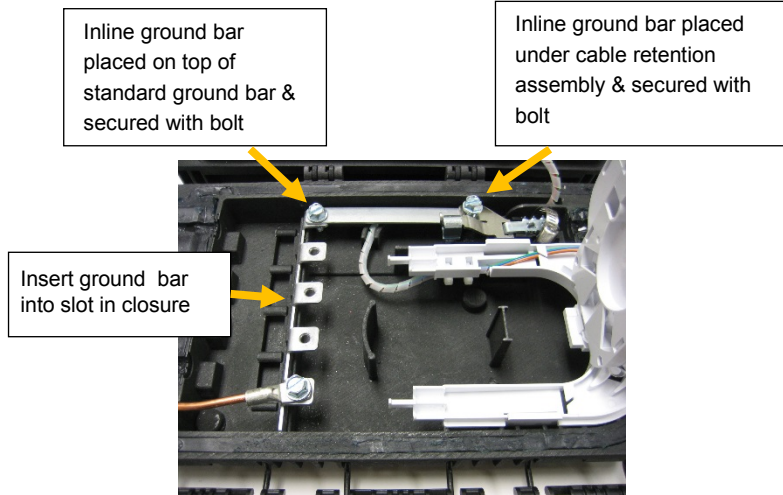

Photo # 122

6.2.3 External ground connection is to be placed in designated location. The ground wire is to be secured using the same bolt that is used to secure the cable retention assembly or secured with bolt. See photo 123.

▶ **Caution:** Do not use braided or stranded ground wire when installing a ground through a port on the Mini-OTE 300 closure. A solid ground wire is required to prevent a leak path and make a proper seal.

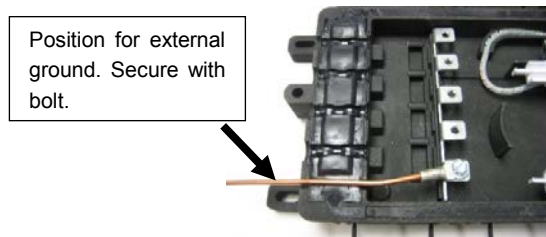

Photo # 123

## 6.3 CABLE RETENTION

6.3.1 If LBT cable, remove any dummy buffer tubes by cutting at cable sheath opening. See photo 124.

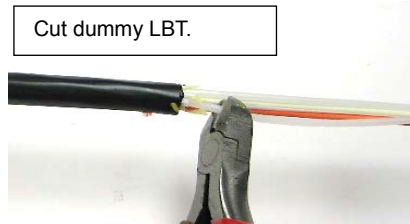

Photo # 124

6.3.2 Open hose clamp on cable retention assembly. Place cable retention assembly around cable. If cable is shielded and to be grounded, orient the sheath opening, which exposes the shielding, toward the base of retention clamp. See photos 125-126.

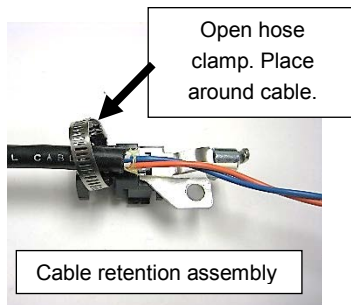

Photo # 125

**Caution:** Cable sheath opening positioned downward.

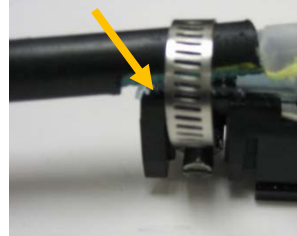

Photo # 126

6.3.3 Insert strength member(s) into lug and hand tighten screw with the tool provided. See photo 127.

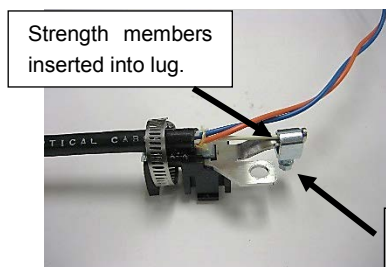

Photo # 127

**Caution:** Tighten lug with nut in downward position



6.3.4 Cut perforated foil into 3 pieces (note orientation) and form over cable. If Flat Drop, wrap around drop. See photos 128-130.

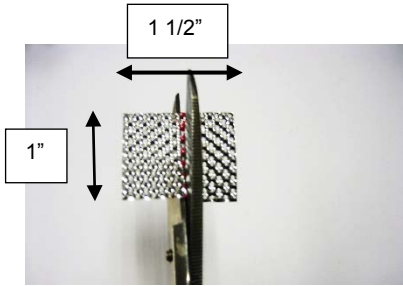

Photo #128

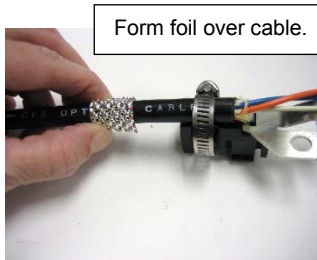

Photo #129



Photo #130

6.3.5 Place 1 pc of perforated foil between the hose clamp and outer sheath of cable. Tighten hose clamp being sure to keep the screw head positioned under the cable retention assembly in order to avoid interference when installing closure. See photos 131-132.

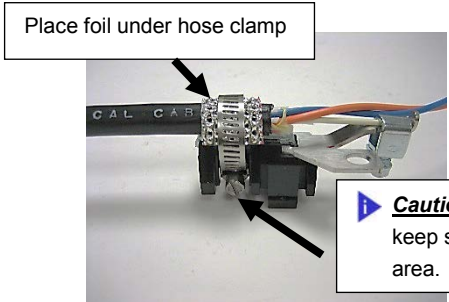

Photo #131

**Caution:** Tighten screw, keep screw in contained area.

**Caution:** If shielded, keep cable positioned as shown, while tightening hose clamp.

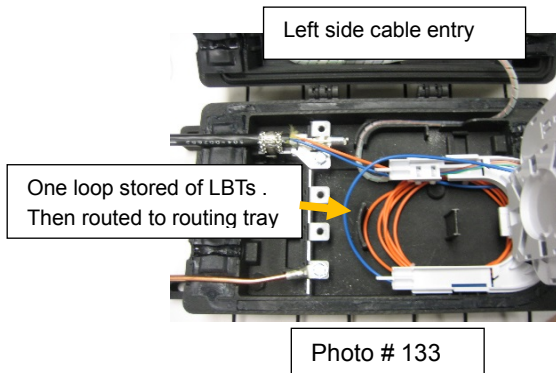

Photo #132

6.3.6 Return to Cable Preparation **Section 6.1.5**

## 6.4 FIBER ORGANIZING/STORAGE, ROUTING AND SPLICING

6.4.1 Store one loop of buffer tube and proceed to routing tray. See photo 133.



6.4.2 Place appropriate grommet onto buffer tube. If more than one buffer tube, both may be installed into one grommet. Insert into routing tray, sliding grommet to align with retaining groove in routing tray. See photos 134-138A.

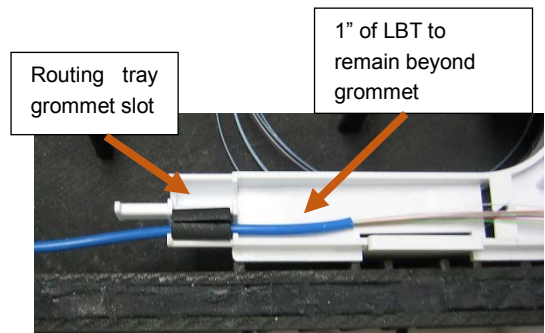
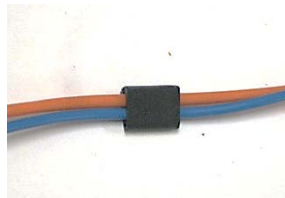
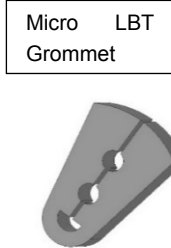
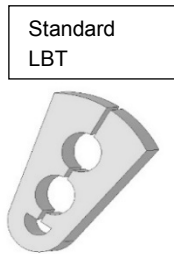
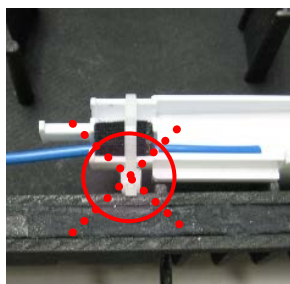

Photo # 134

Photo # 135

Photo # 136

Photo # 137



**Caution:** Secure with cable tie so that it is oriented as shown in photo # 138A

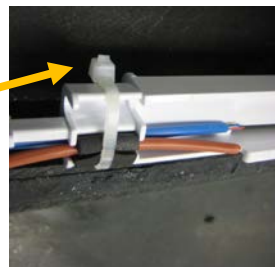

Photo # 138

Photo # 138A

6.4.3 Route fiber(s) that will not be spliced to the Feed Thru tray. See photo 139.

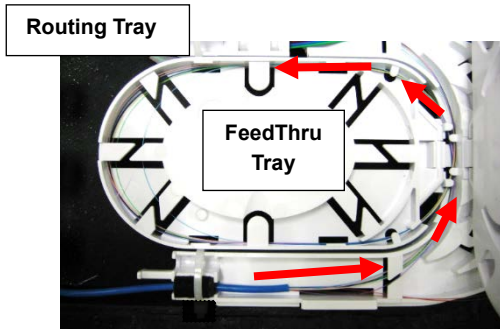

Photo # 139

6.4.4 Route fiber(s) to be spliced to top splice tray. See photos 140-142.

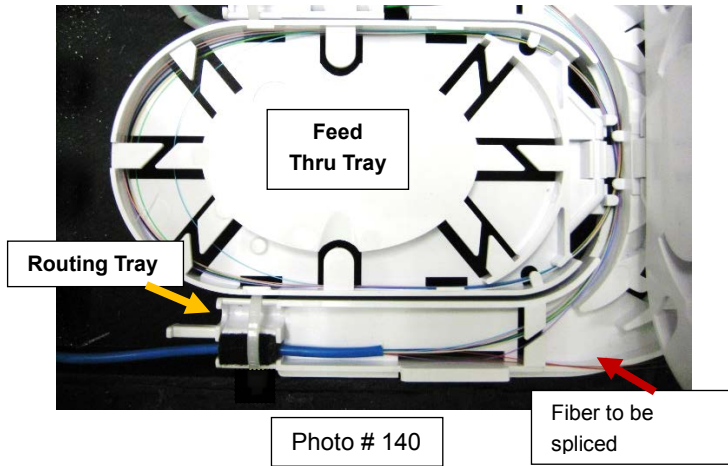

Photo # 140

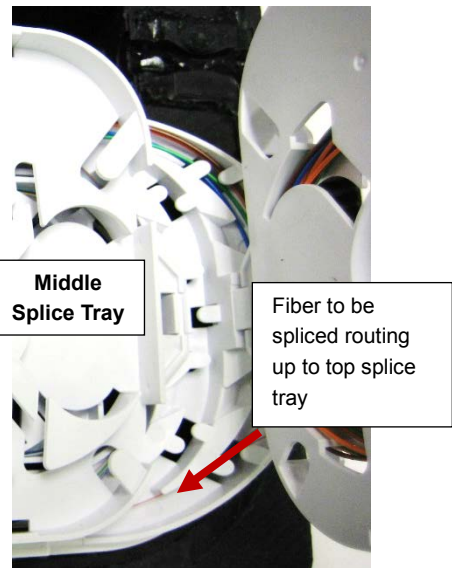

Photo # 141

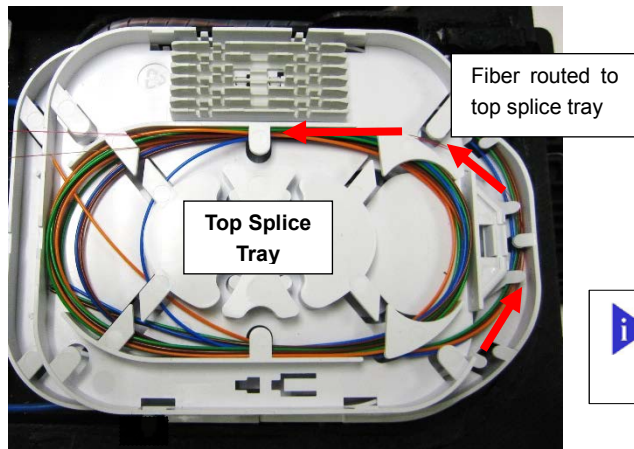

Photo # 142

**Caution:** SMOUVS **must** be centered when placed in the holders.

6.4.5 Splice per standard practice. Replace dust cover on tray after splicing

## 6.5 CLOSING / SECURING CLOSURE

6.5.1 Apply optional routing label inside lid or on tray cover.

6.5.2 Install port plugs into all unused ports including ground port if no ground wire. See photo 143.

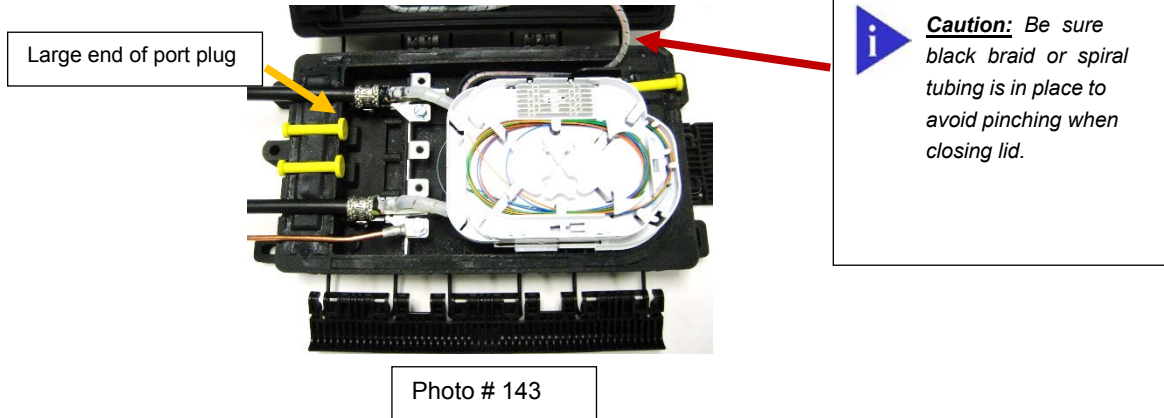

6.5.3 Close lid. Ensure all port plugs, ground wire (if present) and cables are properly aligned. Snap right side hinge, left side hinge, and then top hinge. Hinges can be closed using screwdriver or by hand. See photos 144-146.



6.5.4 Tighten security bolt. See photo 147.

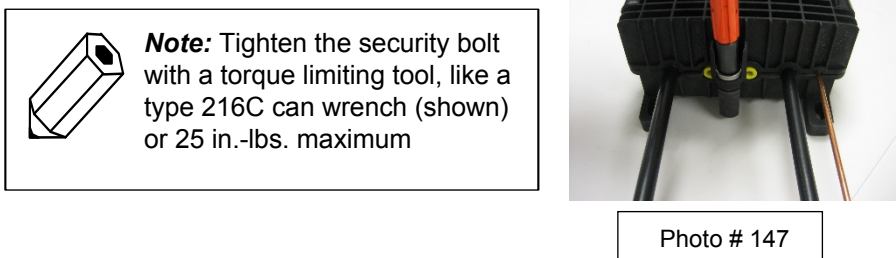

## 6.6 MOUNTING CLOSURE (PEDESTAL, STRAND & POLE MOUNT)

6.6.1 For pedestal mounting, assemble mounting bracket(s) to back of housing. Assemble to plate or rod.  
See photos 36 A-D

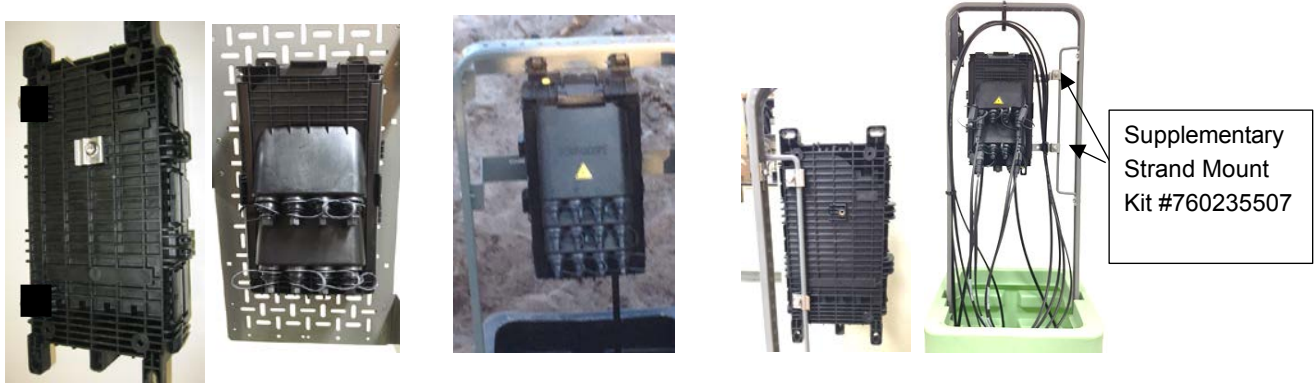

Photos 36 A-D

6.6.2 For strand mounting, assemble strand clamps or supplementary mounting brackets to back of housing. Assemble to line. See photos 36 E – F.

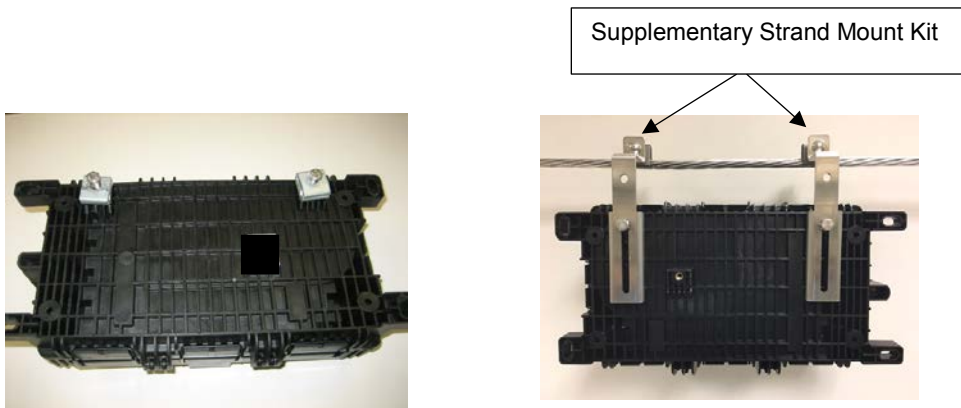

Photos 36 E- F

6.6.3 For pole mounting, assemble supplementary mounting brackets to back of housing and assemble to pole.  
See photo 37.

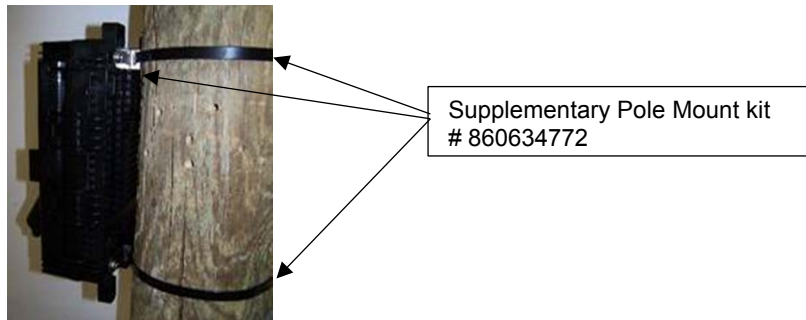

Photo 37

# Chapter 7. Inline Express – Ribbon Central Core Tube Shielded/Unshielded

## 7.0 CABLE PREPARATION

### 7.1 Inline Express (thru) configuration

7.1.1 Preparation of Ribbon Central Core Tube shielded/unshielded, remove 56" of outer sheath. See Figure 10.

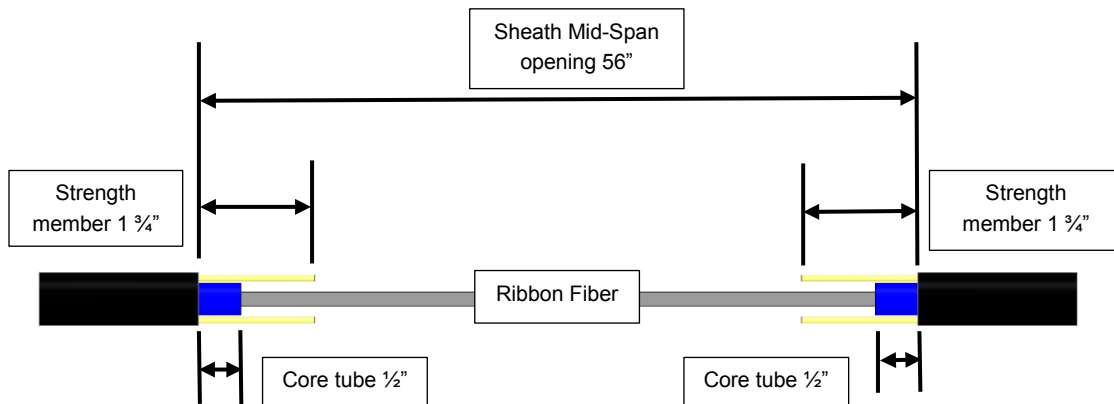



Figure 10

7.1.2 Cut strength member(s) 1 3/4" from end of sheath openings. See Figure 10.

7.1.3 Remove core tube from ribbon leaving 1/2" core tube measured from the cable sheath opening. See Figure 10.

7.1.4 Cut two 1/2" pieces of black felt tape and wrap around each core tube.

 **Note:** Steel strength members may be temporarily bent apart to aid in application of tape. See photos 150-152.

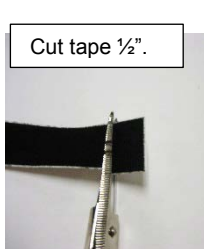

Photo # 150



Photo # 151

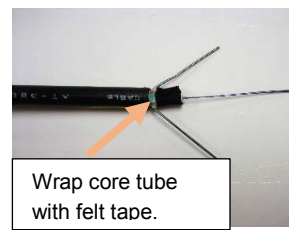

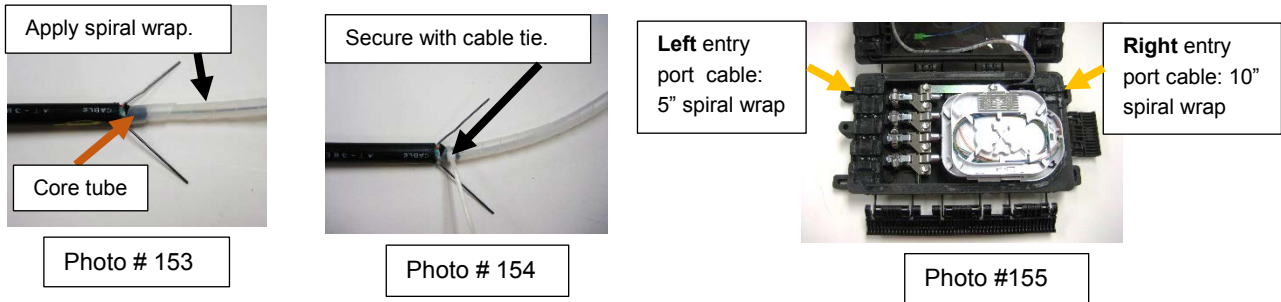

Photo # 152

7.1.5 Cut 2 pieces of spiral wrap, one 5" and one 10" in length.

7.1.6 Wrap the 5" section of spiral wrap around ribbon entering from the **left side** of closure so that it wraps around the 1/2" core tube. Wrap the 10" section of spiral wrap around ribbon entering from the **right side** of closure. Secure each spiral wrap to core tube with cable tie. See photos 153-155.

 **Note:** Straighten steel strength members back into original position.



7.1.7 If cable is shielded and to be grounded, proceed to **Section 7.2**.

7.1.8 Proceed to **Section 7.3** to assemble cable retention hardware.

7.1.9 Snap cable retention assemblies into the appropriate locations. Secure with bolts if grounded. See photos 156-158.

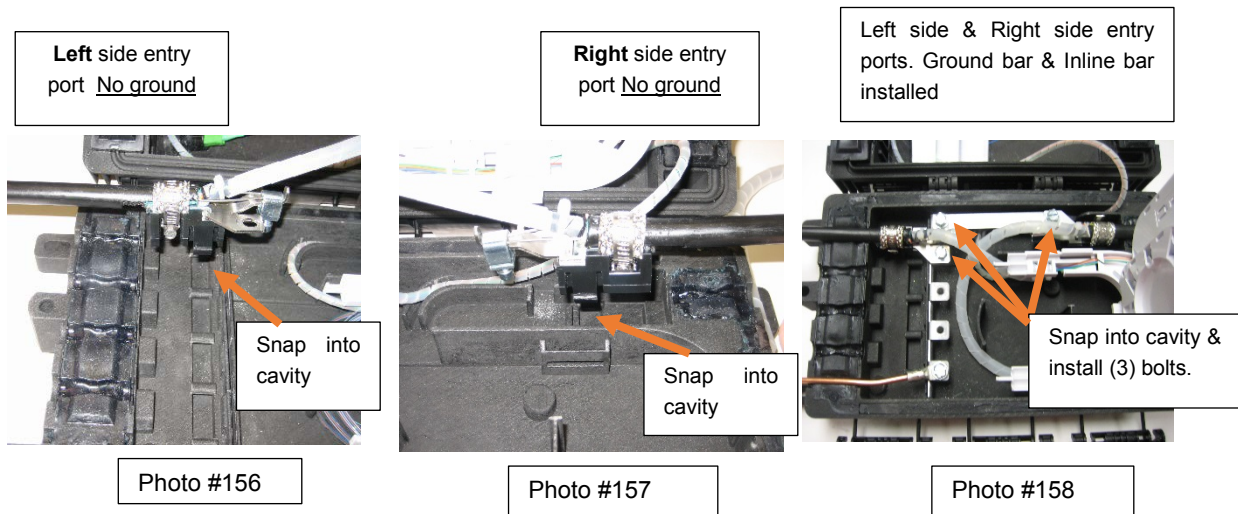

7.1.10 Mark ribbon fibers 46" from the cable jacket opening on incoming signal side of cable.

7.1.11 Remove ribbon containing fiber to be spliced from fiber stack. Store express fibers in storage area starting with fiber entering closure from the right side. See photo 161. Tray stack may be removed for easier access to storage. See photos 159-161.

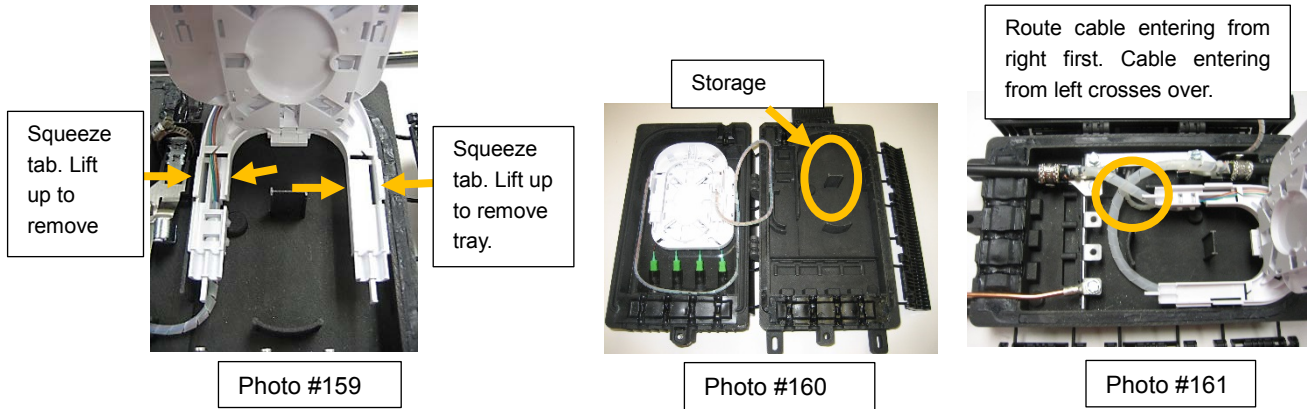

7.1.12 Proceed to **Section 7.4** for Fiber Routing and Splicing.

## 7.2 CABLE & EXTERNAL GROUNDING

7.2.1 For cable with shielding, remove a section of the outer sheath 180° around the cable by 1.0" in length measured from the end of the outer sheath in order to expose cable shielding. See photo 162.

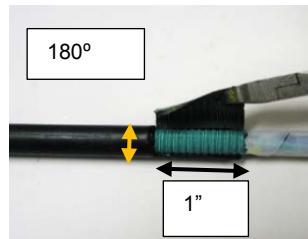
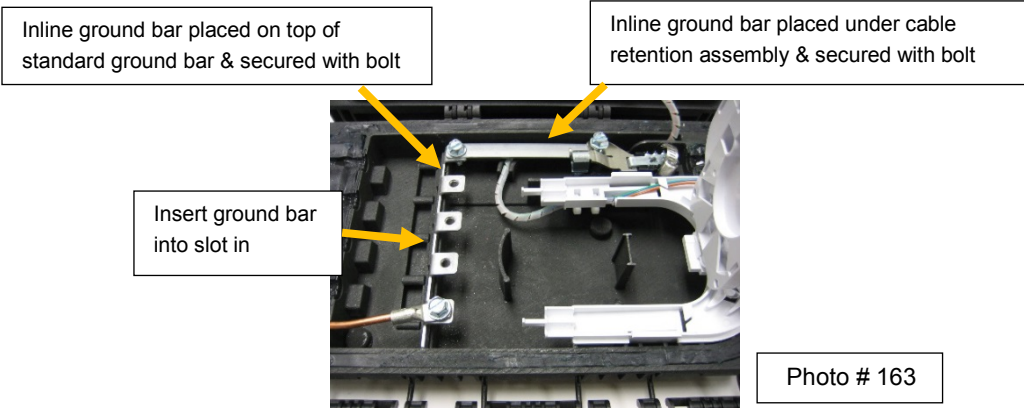

Photo #162

**NOTE:** Exposed shielding will be bonded to the cable retention bracket and ground bar.

7.2.2 For grounding, press ground bar into slot in closure. If using Inline configuration, install inline ground bar and secure with bolt. See photo 163.





7.2.3 External ground connection is to be placed in designated location. The ground wire is to be secured using the same bolt that is used to secure the cable retention assembly. See photo 164.

- ▶ **Caution:** Do not use braided or stranded ground wire when installing a ground through a port on the Mini-OTE 300 closure. A solid ground wire is required to prevent a leak path and make a proper seal.

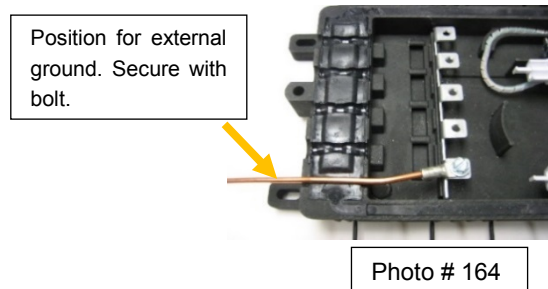

## 7.3 CABLE RETENTION

7.3.1 Open hose clamp on cable retention assembly. Place cable retention assembly around cable. If cable is shielded and to be grounded, orient the sheath opening, which exposes the shielding, toward the base of retention clamp. See photos 165-166.

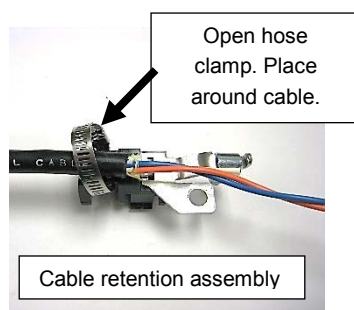

Photo # 165

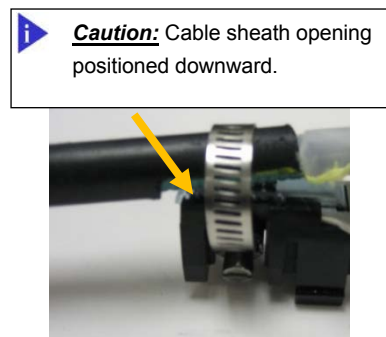

Photo # 166

7.3.2 Insert strength member(s) into lug and hand tighten screw with the tool provided. See photo 167.

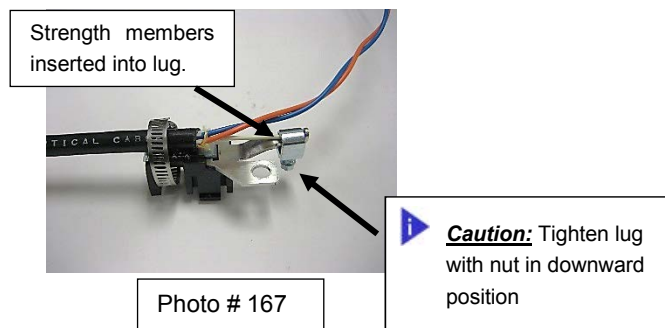

Photo # 167

7.3.4 Cut perforated foil into 3 pieces (note orientation) and form over cable. If Flat Drop, wrap around drop. See photos 168-170.

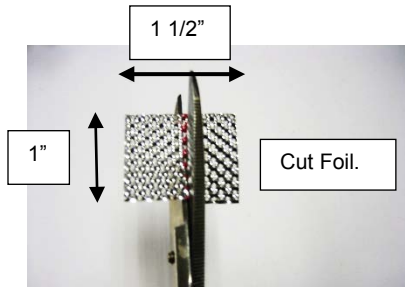

Photo #168

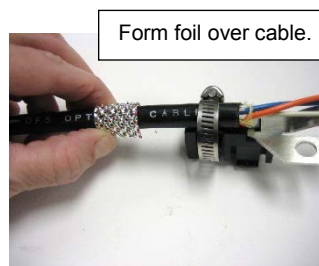

Photo #169



Photo #170

7.3.5 Place 1 pc of perforated foil between the hose clamp and outer sheath of cable. Tighten hose clamp being sure to keep the screw head positioned under the cable retention assembly in order to avoid interference when installing closure. See photos 171-172.

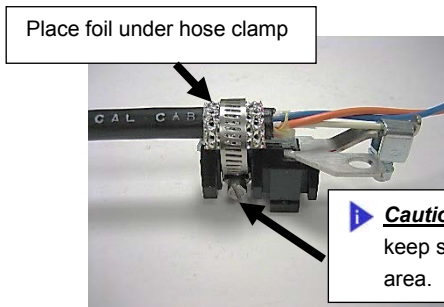

Photo #171



Photo #172

7.3.6 Return to Cable Preparation **Section 7.1.9.**

## 7.4 FIBER ORGANIZING/STORAGE, ROUTING AND SPLICING

### 7.4.1 INLINE EXPRESS (thru) configuration Ribbon Central Core Tube Shielded/Unshielded

7.4.2 Route ribbon to tray entry points and mark ribbon 1" beyond grommet locations. De-ribbonize fiber between marks. See photos 173-174.

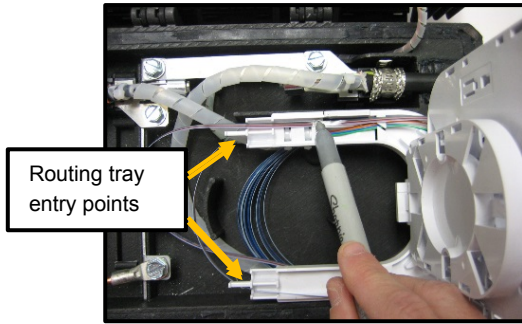

Photo #173

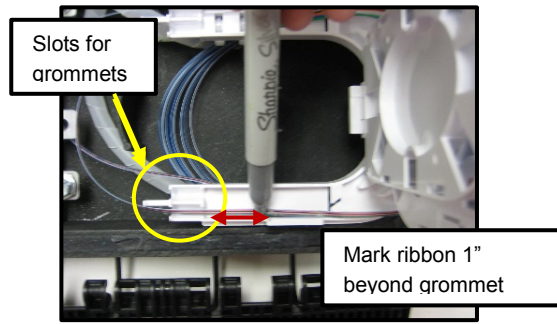

Photo #174

7.4.3 Install ribbon grommets onto ribbon one inch before de-ribbonize point. Install grommets into routing tray and secure with cable tie. See photos 175-177A.

Ribbon grommet



Photo #175

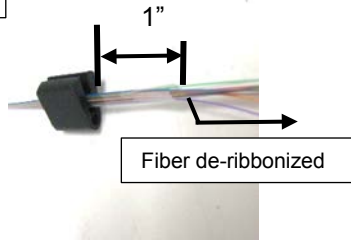

Photo #176



Photo # 177

**Caution:** Secure with cable tie so that it is oriented as shown in photo # 177A

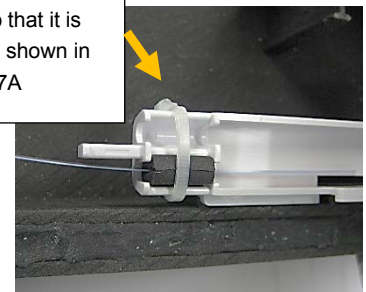

Photo # 177A

7.4.4 Repeat steps 7.4.2 – 7.4.3 with fiber coming from other end of cable.

7.4.5 Cut fibers to be spliced 41" from the signal input side.

7.4.6 Route express fibers onto feed thru tray. See photo 178.

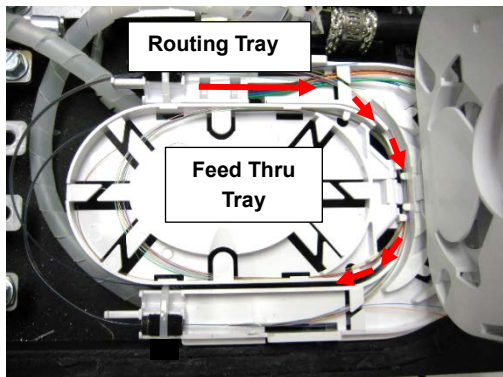

Photo #178

7.4.7 Route fibers to be spliced to top tray. See photos 179-181.

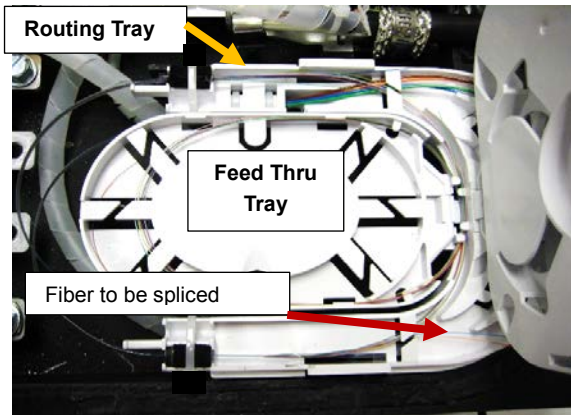

Photo #179

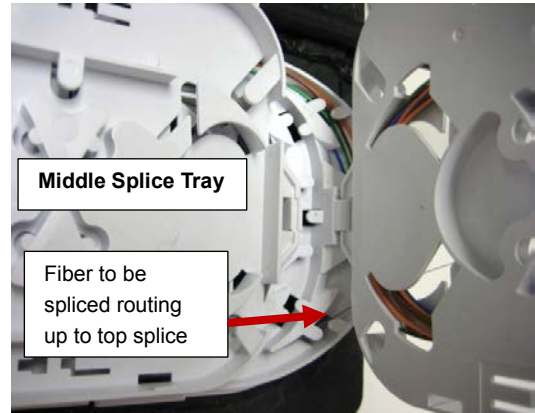

Photo #180

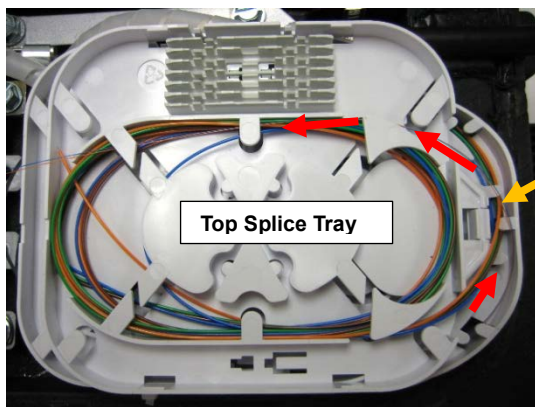

Photo #181

Fiber to be spliced routing up to top splice

**Caution:** SMOUVS **must** be centered when placed in the holders.

7.4.8 Splice per standard practice. Replace dust cover on tray after splicing.

## 7.5 CLOSING / SECURING CLOSURE

7.5.1 Apply optional routing label inside lid or on tray cover.

7.5.2 Install port plugs into all unused ports. Including ground port if no ground wire. See photo 182.

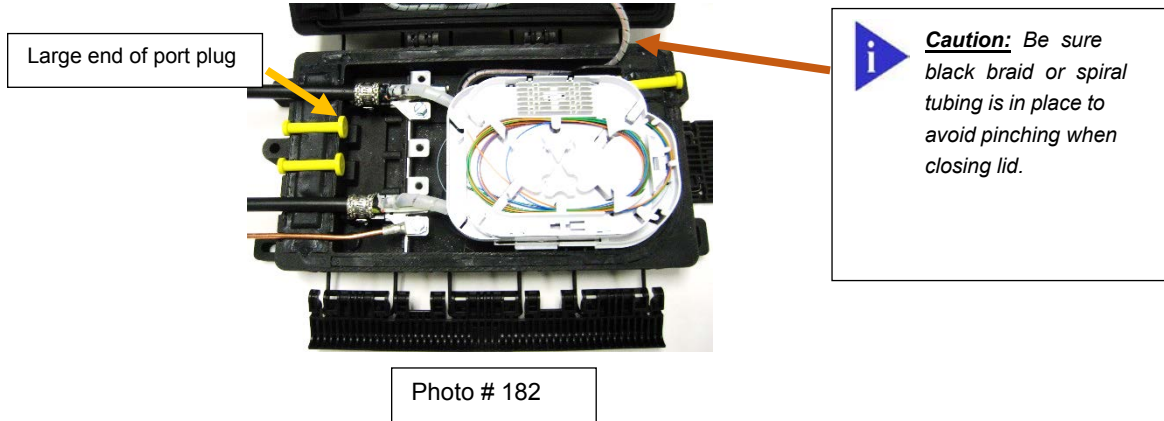

7.5.3 Close lid. Ensure all port plugs, ground wire (if present) and cables are properly aligned.

Snap right side hinge, left side hinge, then top hinge. Hinges can be closed using **screwdriver** or **by hand**. See photos 183-185.

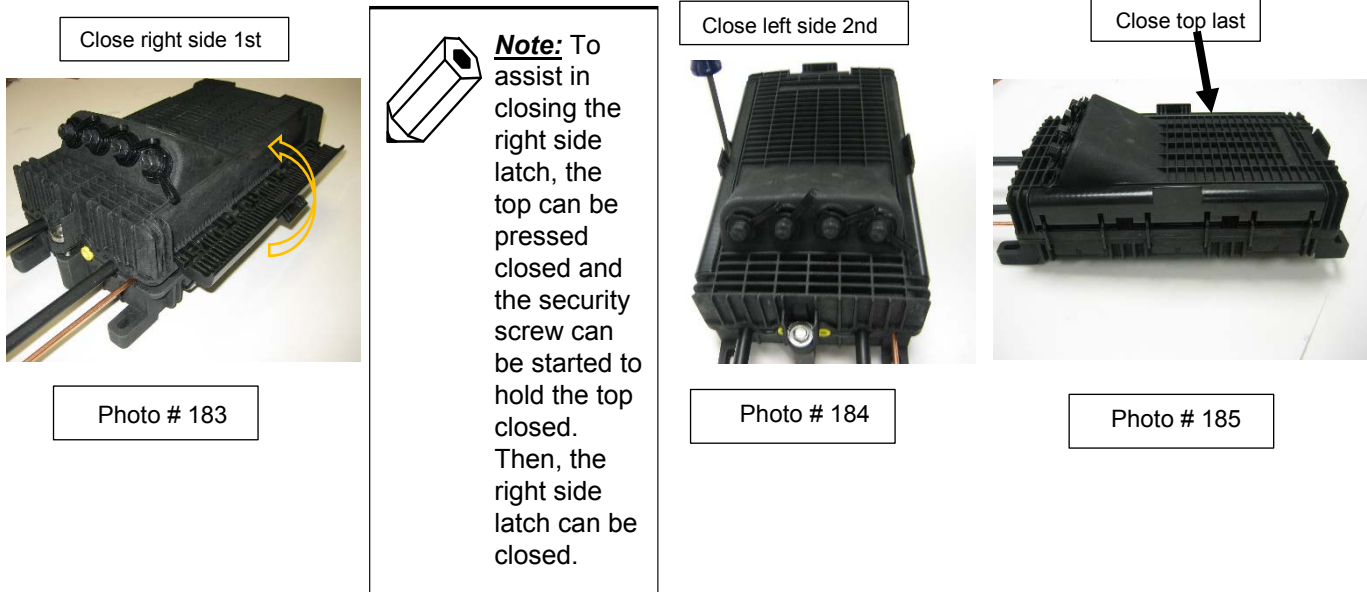

7.5.4 Tighten security bolt. See photo 186.

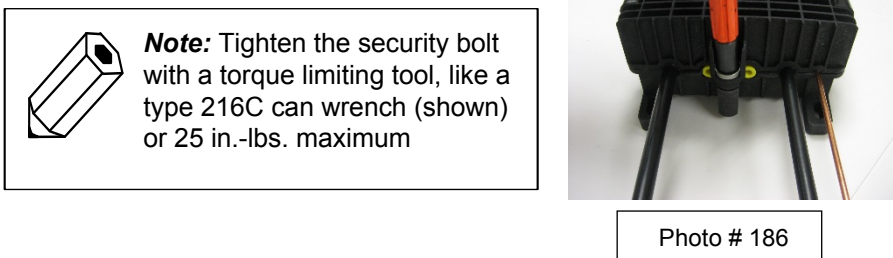

## 7.6 MOUNTING CLOSURE (PEDESTAL, STRAND & POLE MOUNT)

7.6.1 For pedestal mounting, assemble mounting bracket(s) to back of housing. Assemble to plate or rod.  
See photos 36 A-D

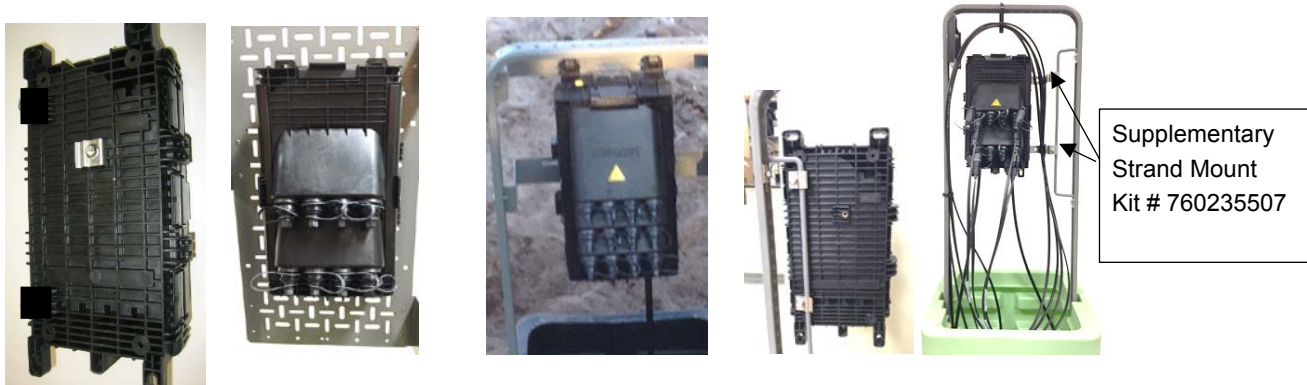

Photos 36 A-D

7.6.2 For strand mounting, assemble strand clamps or supplementary mounting brackets to back of housing. Assemble to line. See photos 36 E – F.

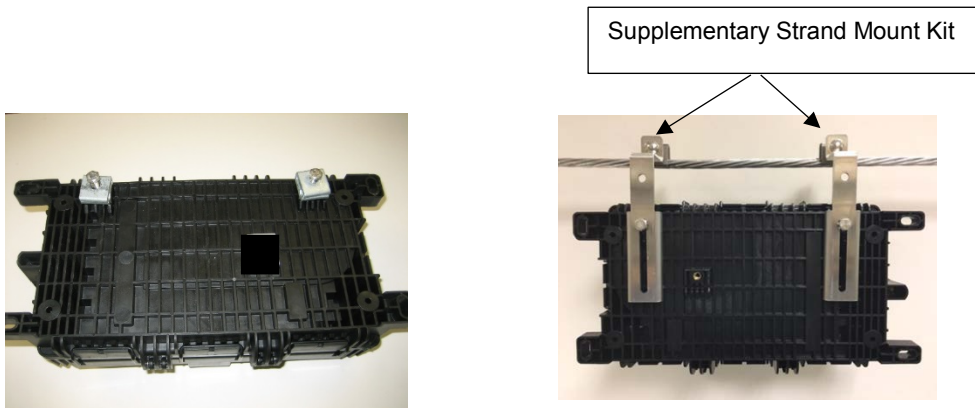

Photos 36 E- F

7.6.3 For pole mounting, assemble supplementary mounting brackets to back of housing and assemble to pole.  
See photo 37.

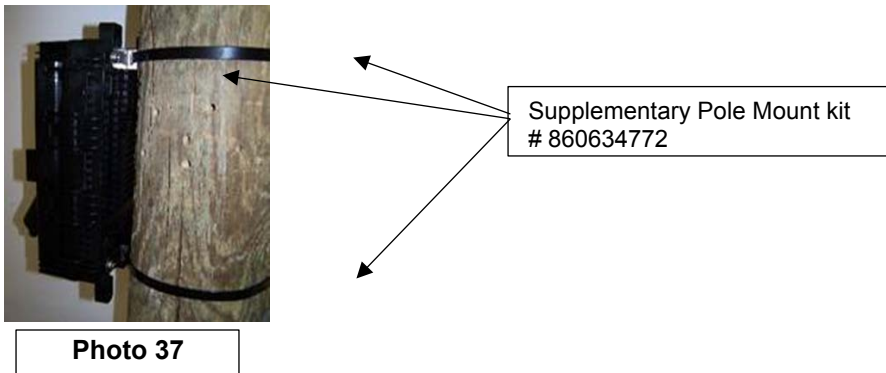

Photo 37

# Chapter 8. Butt Express – Ribbon Central Core Tube Shielded/Unshielded

## 8.0 CABLE PREPARATION

### 8.1 Butt Express (thru) configuration

8.1.1 Preparation of Ribbon Central Core Tube shielded/unshielded, remove 56" of outer sheath. See Figure 11.

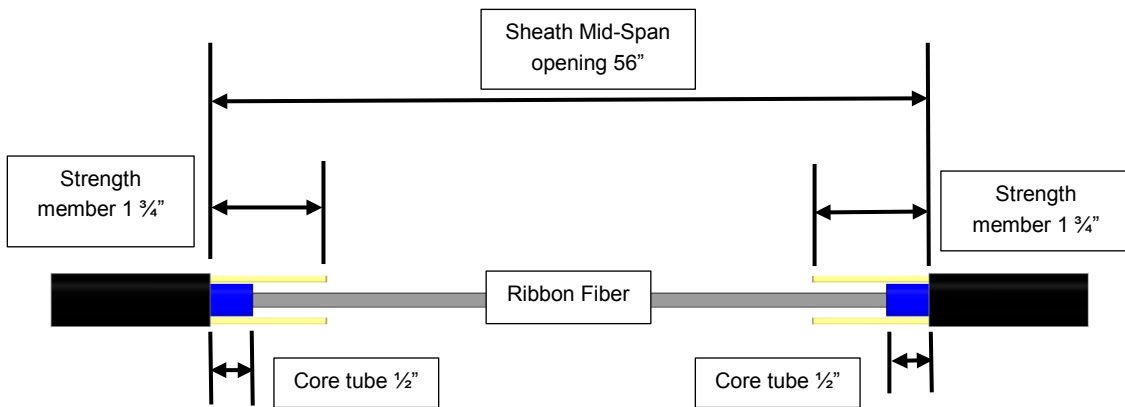

Figure 11

8.1.2 Cut strength member(s) 1 3/4" from end of sheath openings. See Figure 11.

8.1.3 Remove core tube from ribbon leaving 1/2" core tube measured from the cable sheath openings. See Figure 11.

8.1.4 Cut two 1/2" pieces of black felt tape and wrap around each core tube.

**Note:** Steel strength members may be temporarily bent apart to aid in application of tape. See photos 189-191.

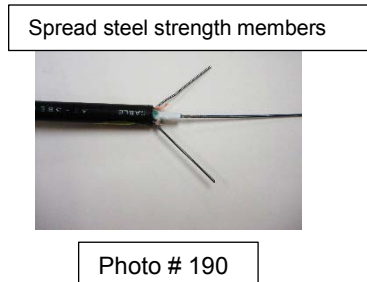

8.1.5 Cut 2 pieces of spiral wrap each 5".

8.1.6 Wrap the 5" section of spiral wrap around ribbon so that it wraps around the ½" core tube. Secure each spiral wrap to core tube with cable tie. Repeat on other side of sheath opening. See photos 192-193.

**Note:** Straighten steel strength members back into original position

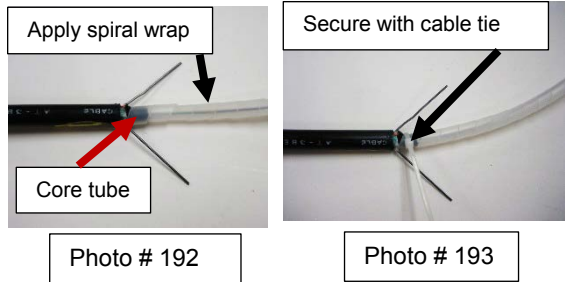

8.1.7 If cable is shielded and to be grounded, proceed to **Section 8.2**.

8.1.8 Proceed to **Section 8.3** to assemble cable retention hardware.

8.1.9 Snap cable retention assemblies into the appropriate locations. Secure with bolts if grounded. See photos 194-196.

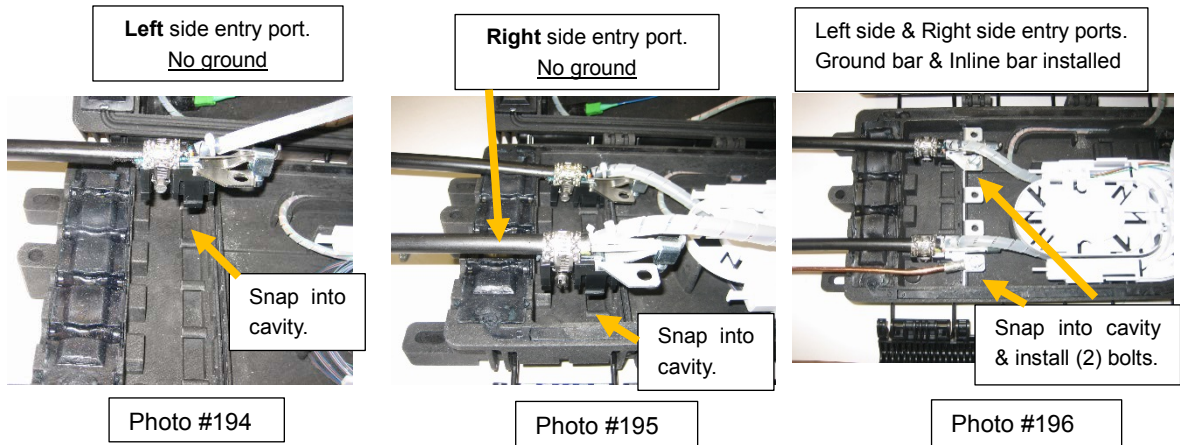

8.1.10 Mark point of ribbon containing fibers to be spliced, 51" from sheath opening where signal input comes from.

8.1.11 Remove ribbon containing fiber to be spliced from fiber stack. Store express fibers in storage area. Tray stack may be removed for easier access to storage. See photos 197-199.

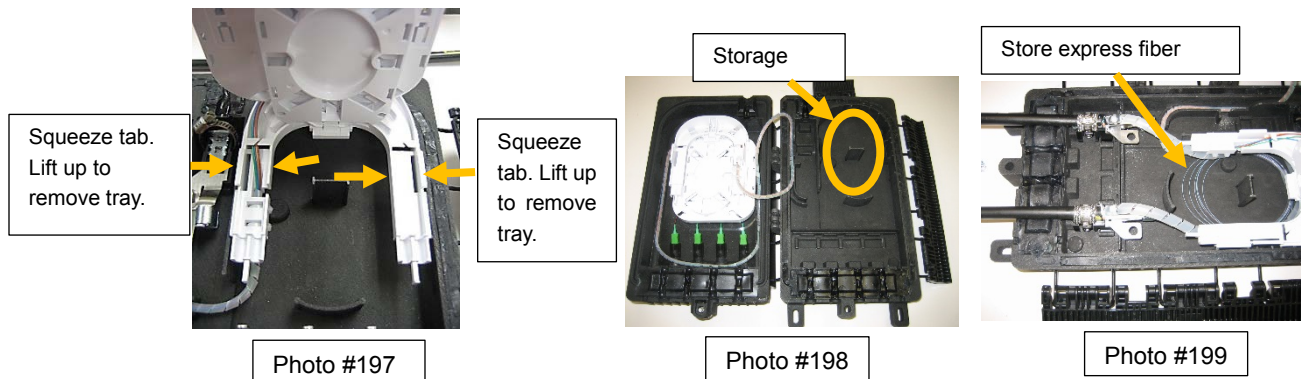

8.1.12 Proceed to **section 8.4** for Fiber Routing and Splicing.



## 8.2 CABLE & EXTERNAL GROUNDING

8.2.1 For cable with shielding, remove a section of the outer sheath 180° around the cable by 1.0” in length measured from the end of the outer sheath in order to expose cable shielding. See photo 200.

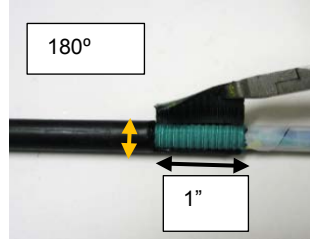



Photo #200

 **NOTE:** Exposed shielding will be bonded to the cable retention bracket and ground bar.

8.2.2 For grounding, press ground bar into slot in closure. If using Inline configuration, install inline ground bar and secure with bolt. See photo 201.

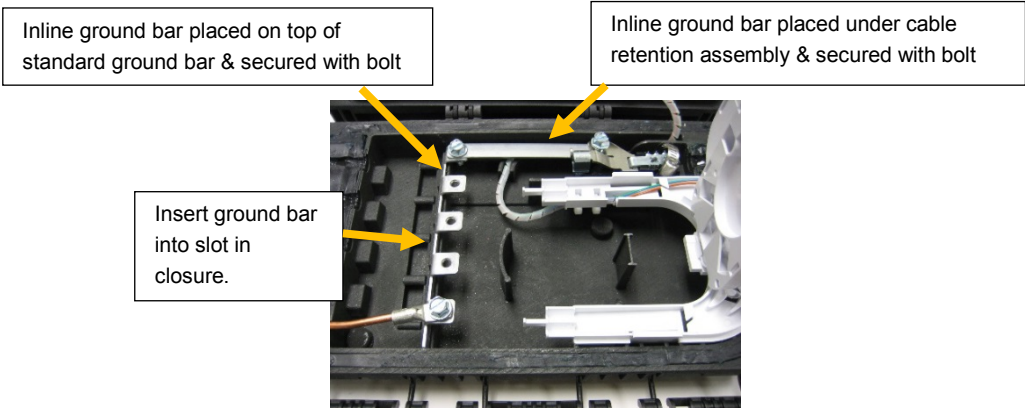

Photo # 201

8.2.3 External ground connection is to be placed in designated location. The ground wire is to be secured using the same bolt that is used to secure the cable retention assembly. See photo 202.

▶ **Caution:** Do not use braided or stranded ground wire when installing a ground through a port on the Mini-OTE 300 closure. A solid ground wire is required to prevent a leak path and make a proper seal.

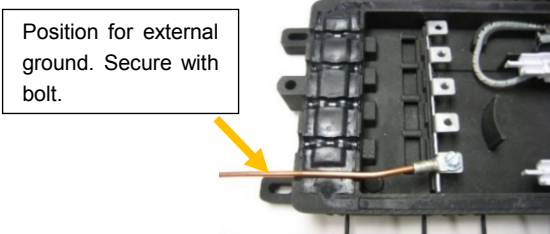
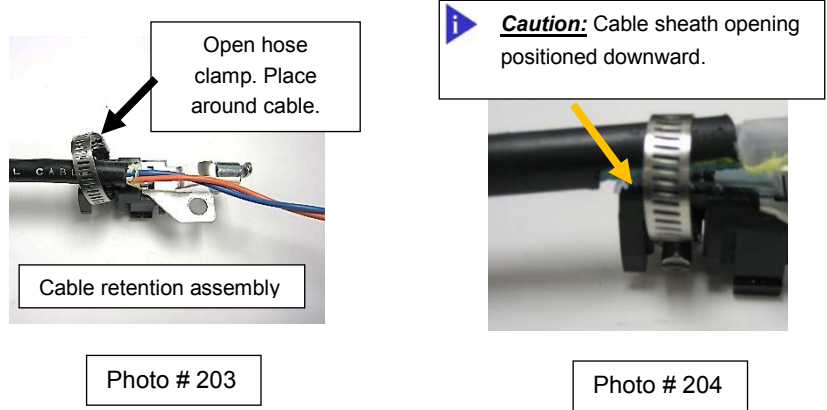

Photo # 202

## 8.3 CABLE RETENTION

8.3.1 Open hose clamp on cable retention assembly. Place cable retention assembly around cable. If cable is shielded and to be grounded, orient the sheath opening, which exposes the shielding, toward the base of retention clamp. See photos 203-204.



8.3.2 Insert strength member(s) into lug and hand tighten screw with the tool provided. See photo 205.

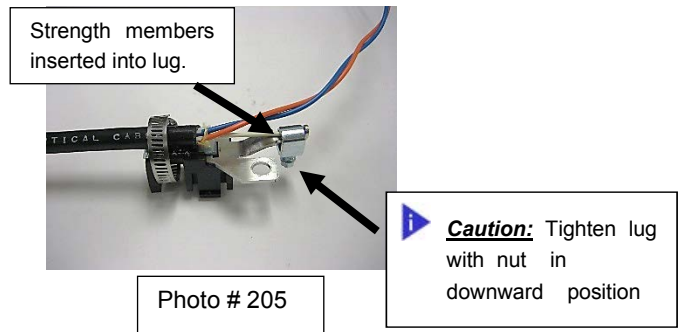

8.3.4 Cut perforated foil into 3 pieces (note orientation) and form over cable. If Flat Drop, wrap around drop. See photos 206-208.

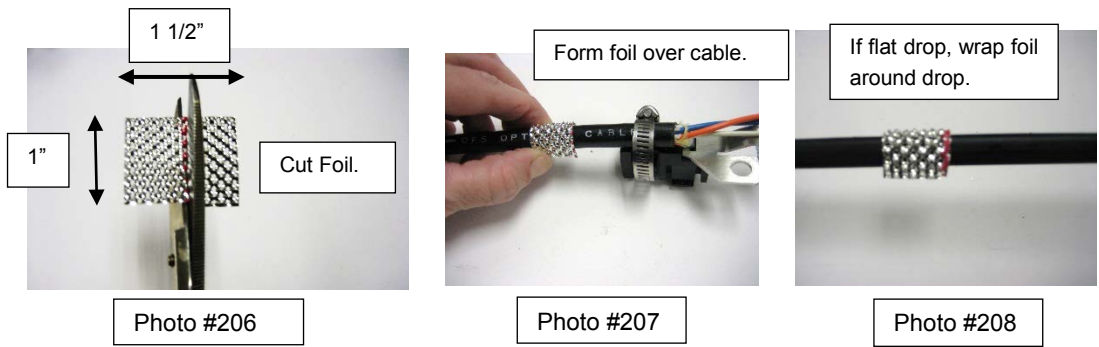

8.3.5 Place 1 pc of perforated foil between the hose clamp and outer sheath of cable. Tighten hose clamp being sure to keep the screw head positioned under the cable retention assembly in order to avoid interference when installing closure. See photos 209-210.

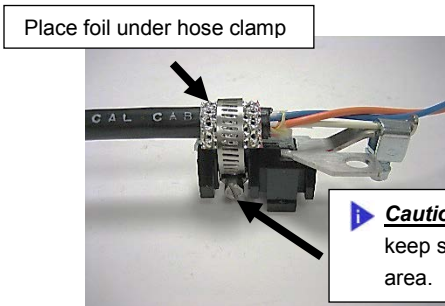

Photo #209

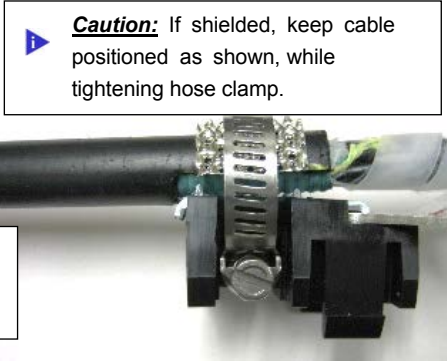

Photo #210

8.3.6 Return to Cable Preparation **Section 8.1.9.**

## 8.4 FIBER ORGANIZING/STORAGE, ROUTING AND SPLICING

8.4.1 BUTT EXPRESS (thru) configuration Ribbon Central Core Tube Shielded/Unshielded Place one loop of ribbon fiber to be spliced, in storage area.

8.4.2 Route ribbon to tray entry points and mark ribbon 1" beyond grommet locations. De-ribbonize fiber between marks. See photos 211-212.

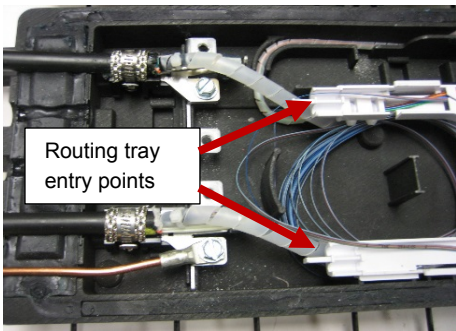

Photo #211

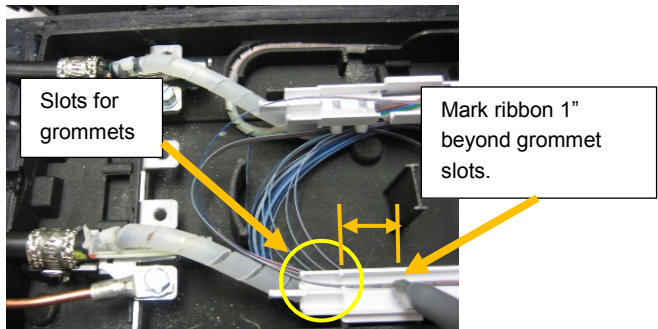

Photo #212

8.4.3 Install ribbon grommets onto ribbon 1" before de-ribbonize point. Install grommets into routing tray and secure with cable tie. See photos 213-215A.

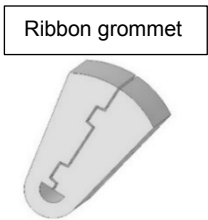

Photo #213

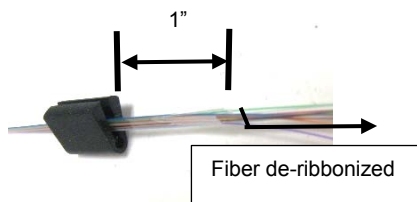

Photo #214

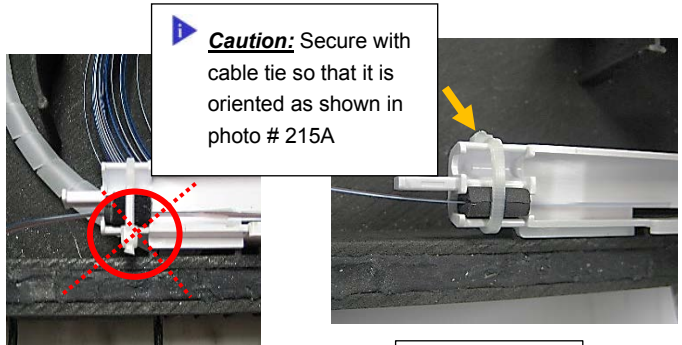

Photo # 215

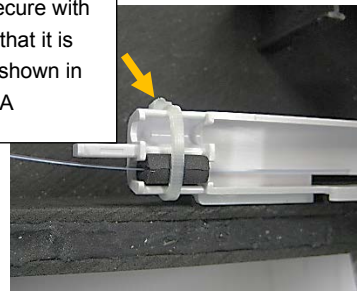

Photo # 215A

8.4.4 Cut fibers to be spliced 51" from end of spiral wrap measured from signal side of cable..

### Mini-OTE 300 Installation Guide

All trademarks used in this publication are CommScope registered 2019 CommScope Inc. All rights Reserved

8.4.5 Route express fibers and “dead to field” onto Feed Thru tray. See photo 216.

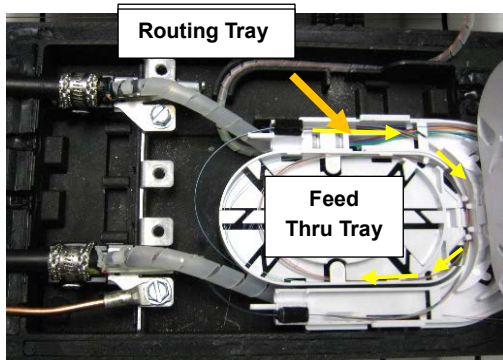

Photo #216

8.4.6 Route fibers to be spliced to top splicing tray. See photos 217-219.

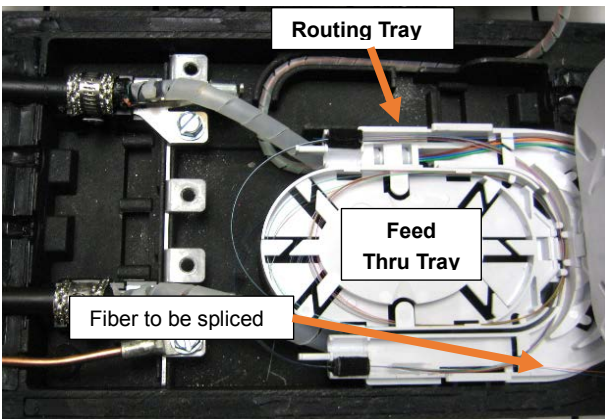

Photo #217

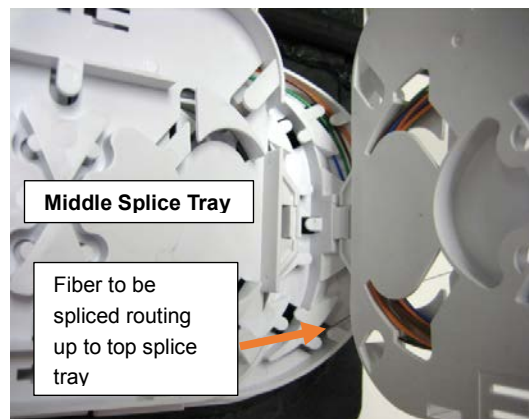

Photo #218

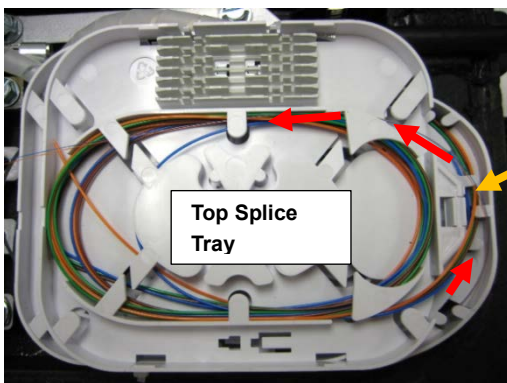

Photo #219

Fiber to be spliced routing up to top splice tray

**Caution:** SMOUVS **must** be centered when placed in the holders.

8.4.7 Splice per standard practice. Replace dust cover on tray after splicing.

## 8.5 CLOSING / SECURING CLOSURE

8.5.1 Apply optional routing label inside lid or on tray cover.

8.5.2 Install port plugs into all unused ports, including ground port if no ground wire. See photo 220.

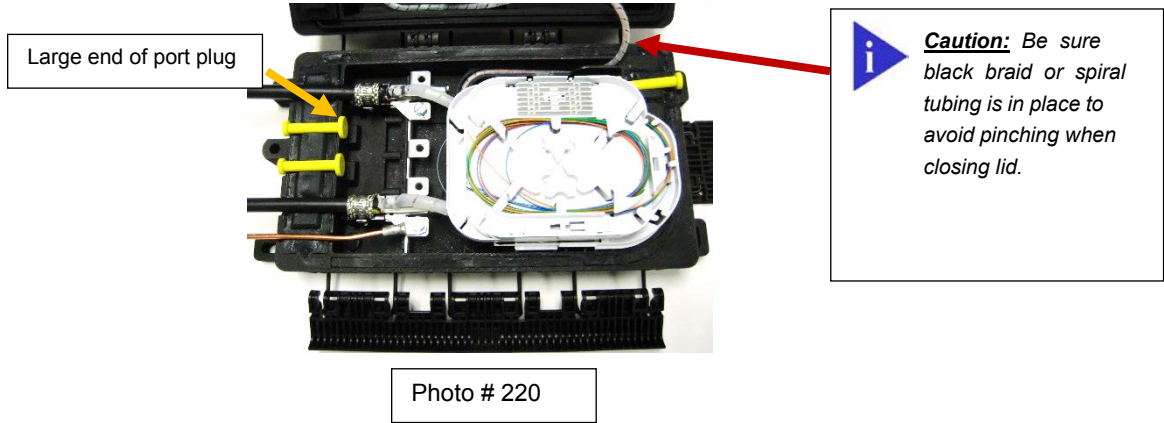

8.5.3 Close lid. Ensure all port plugs, ground wire (if present) and cables are properly aligned.

Snap right side hinge, left side hinge, then top hinge. Hinges can be closed using **screwdriver** or **by hand**. See photos 221-223.



8.5.4 Tighten security bolt. See photo 224

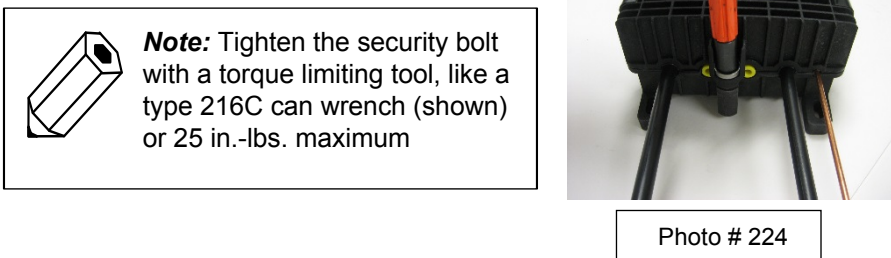

## 8.6 MOUNTING CLOSURE (PEDESTAL, STRAND & POLE MOUNT)

8.6.1 For pedestal mounting, assemble mounting bracket(s) to back of housing. Assemble to plate or rod.  
See photos 36 A-D

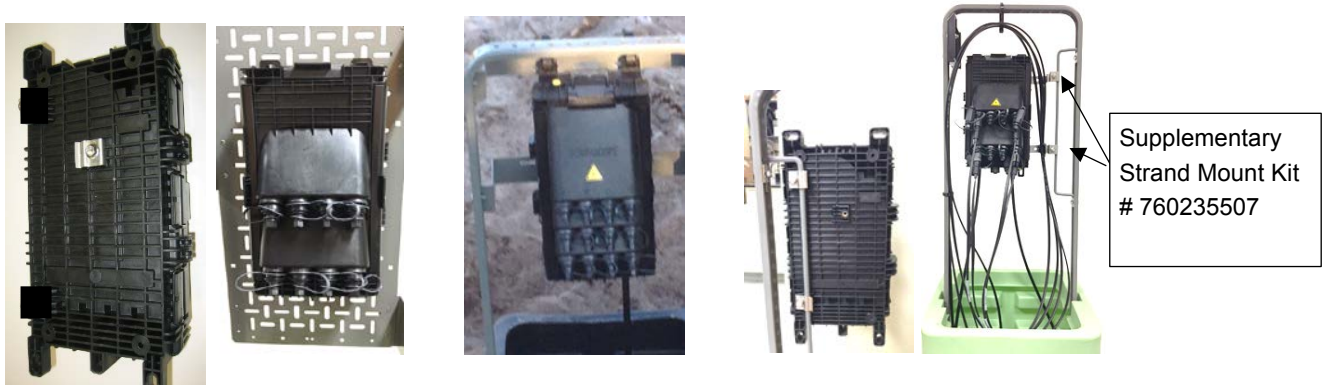

Photos 36 A-D

8.6.2 For strand mounting, assemble strand clamps or supplementary mounting brackets to back of housing.  
Assemble to line. See photos 36 E – F.

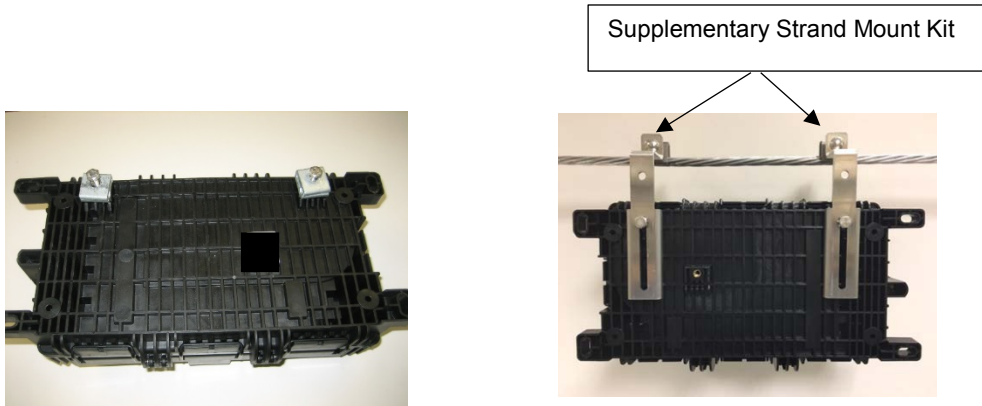

Photos 36 E- F

8.6.3 For pole mounting, assemble supplementary mounting brackets to back of housing and assemble to pole.  
See photo 37.



Photo 37



# Chapter 9. Inline Stub – Ribbon Central Core Tube Shielded/Unshielded

## 9.0 CABLE PREPARATION

### 9.1 Inline Stub (cable end) configuration

9.1.1 Preparation of Inline stub configuration ribbon central core tube, remove 55" of outer sheath from end of cable. See Figure 12.

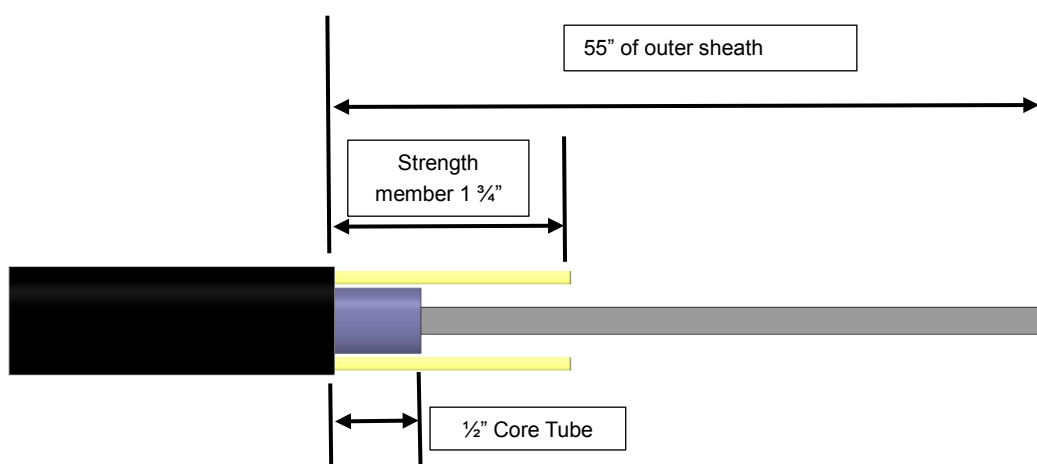

Figure 12

9.1.2 Cut strength member(s) 1 3/4" from end of sheath opening. See Figure 12.

9.1.3 Remove core tube from ribbon leaving 1/2" core tube, measured from the cable sheath openings. See Figure 12.

9.1.4 Cut one 1/2" long piece of black felt tape and wrap around core tube. See photos 227-229.

 **Note:** Steel strength members may be temporarily bent apart to aid in application of tape. See photos 227-229.



Photo # 227



Photo #228

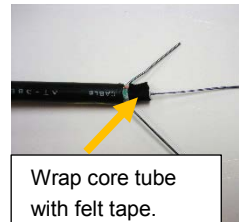

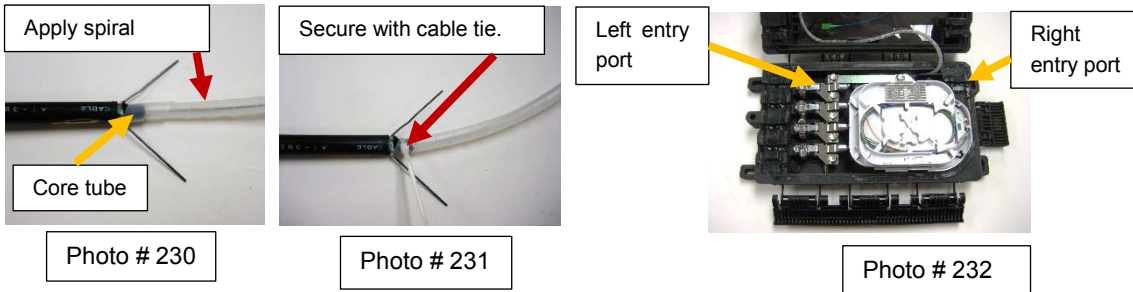

Photo #229

9.1.5 Cut 1 piece of spiral wrap 10" in length.

9.1.6 Wrap spiral wrap around ribbon so that it wraps around the 1/2" core tube. Secure with cable tie. See photos 230-232.

 **Note:** Straighten steel strength members back into original position.



9.1.7 If cable is shielded and to be grounded, proceed to **Section 9.2**, Cable and External Grounding.

9.1.8 Proceed to **Section 9.3**, Cable Retention

9.1.9 Snap cable retention assembly into the appropriate location. Secure with bolts if grounded. See photos 233-235.

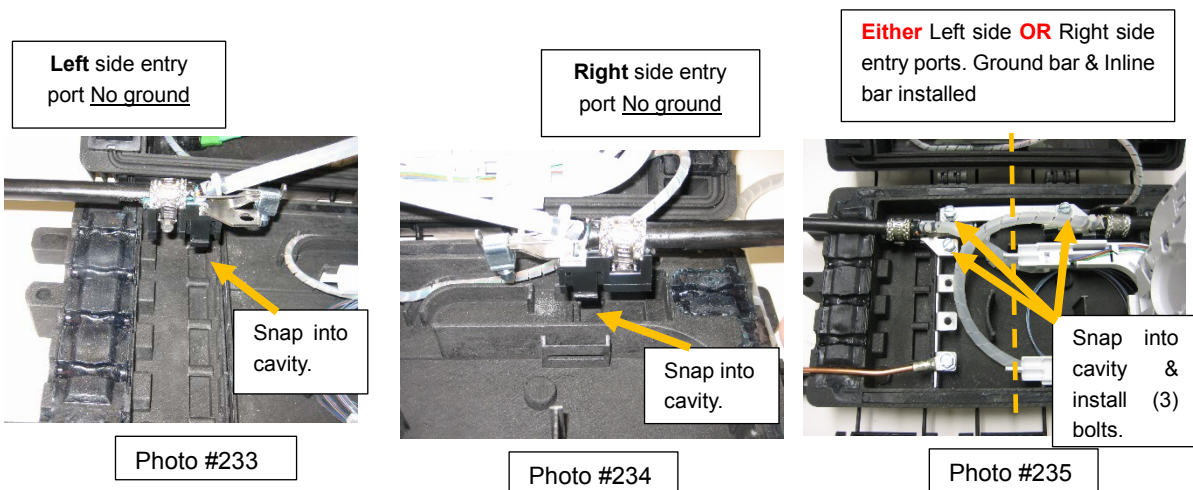

9.1.10 Remove ribbon containing fiber(s) to be spliced from fiber stack.



9.1.11 If ribbons are not to be spliced, route to storage area. Tray stack may be removed for easier access to storage. See photos 236-239.

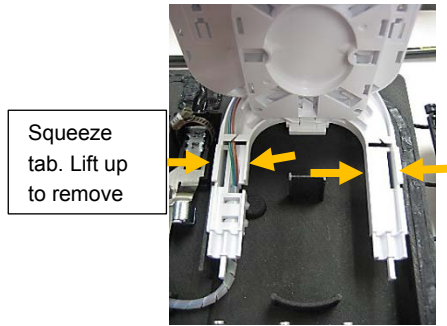

Photo #236

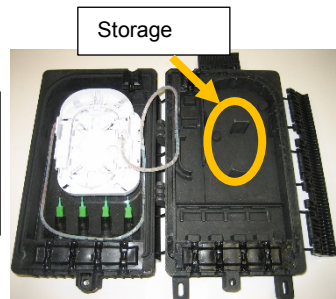

Photo #237

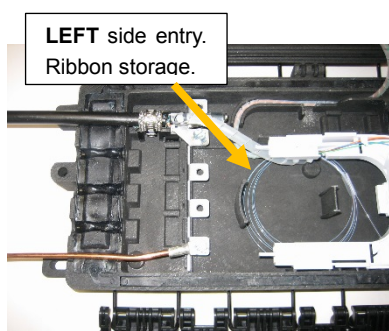

Photo #238

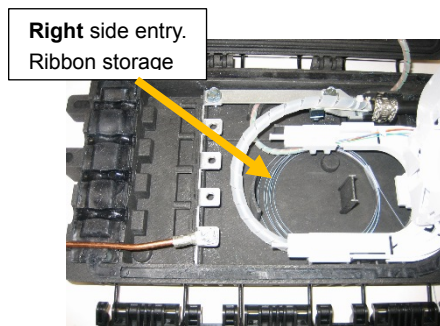

Photo #239

9.1.12 Proceed to **Section 9.4**, for Fiber Routing and Splicing.

## 9.2 CABLE & EXTERNAL GROUNDING

9.2.1 For cable with shielding, remove a section of the outer sheath 180° around the cable by 1.0" in length measured from the end of the outer sheath in order to expose cable shielding. See photo 240.

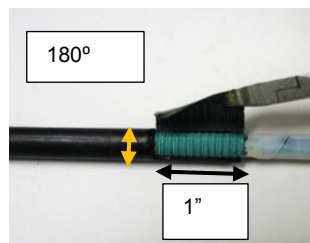
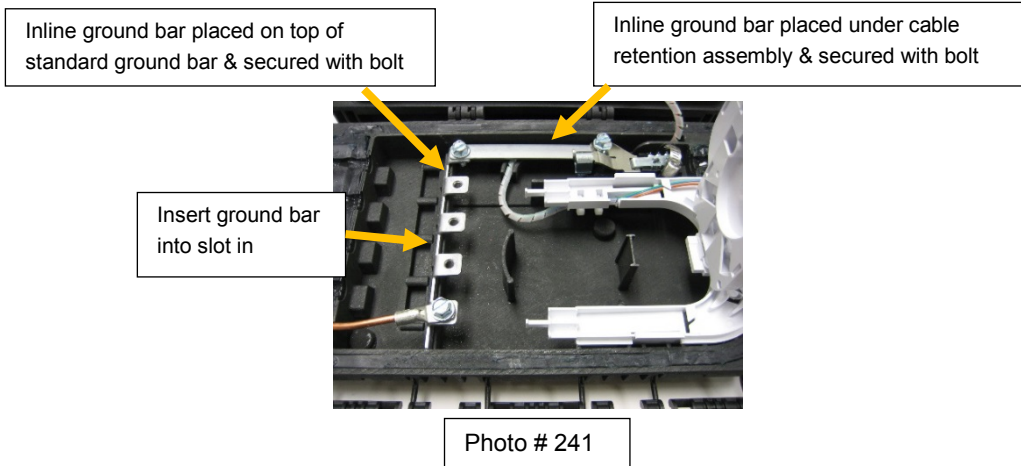

Photo #240



**NOTE:** Exposed shielding will be bonded to the cable retention bracket and ground bar.

9.2.2 For grounding, press ground bar into slot in closure. If using Inline configuration, install inline ground bar and secure with bolt. See photo 241.



9.2.3 External ground connection is to be placed in designated location. The ground wire is to be secured using the same bolt that is used to secure the cable retention assembly. See photo 242.

▶ **Caution:** Do not use braided or stranded ground wire when installing a ground through a port on the Mini-OTE 300 closure. A solid ground wire is required to prevent a leak path and make a proper seal.

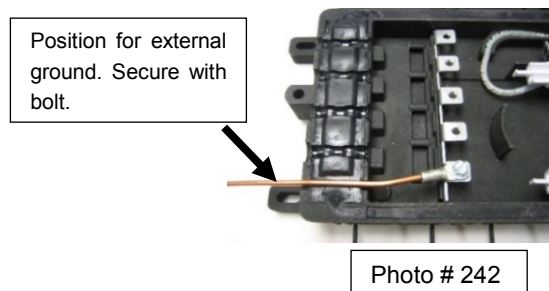

## 9.3 CABLE RETENTION

9.3.1 Open hose clamp on cable retention assembly. Place cable retention assembly around cable. If cable is shielded and to be grounded, orient the sheath opening, which exposes the shielding, toward the base of retention clamp. See photos 243-244.

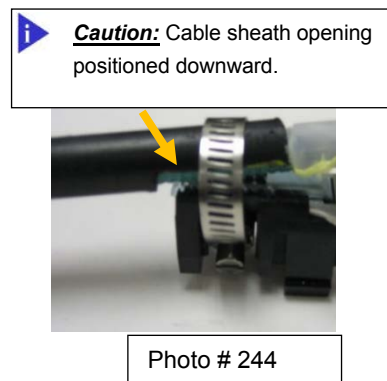
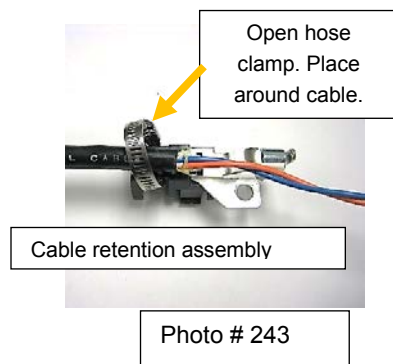

9.3.2 Insert strength member(s) into lug and hand tighten screw with the tool provided. See photo 245.

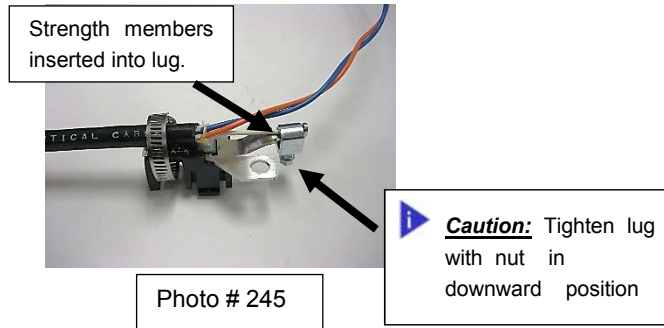

Photo # 245

9.3.4 Cut perforated foil into 3 pieces (note orientation) and form over cable. If Flat Drop, wrap around drop. See photos 246-248.

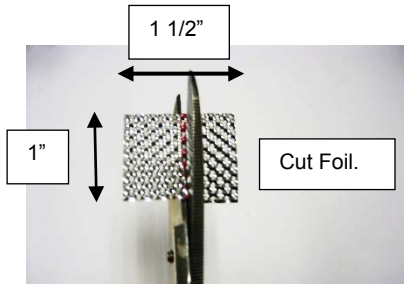

Photo #246

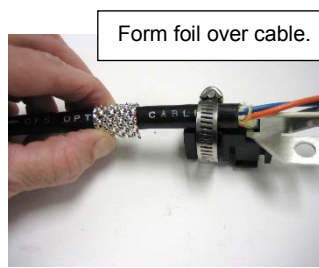

Photo #247

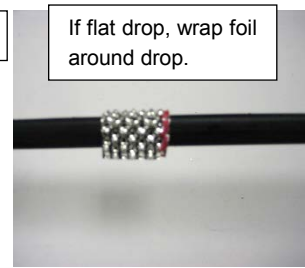

Photo #248

9.3.5 Place 1 pc of perforated foil between the hose clamp and outer sheath of cable. Tighten hose clamp being sure to keep the screw head positioned under the cable retention assembly in order to avoid interference when installing closure. See photos 249-250.

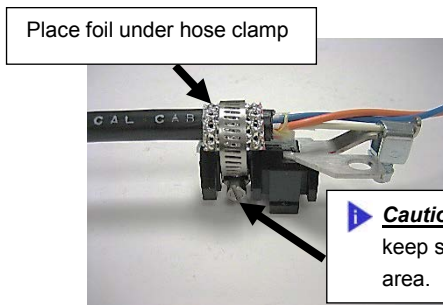

Photo #249

**Caution:** Tighten screw, keep screw in contained area.

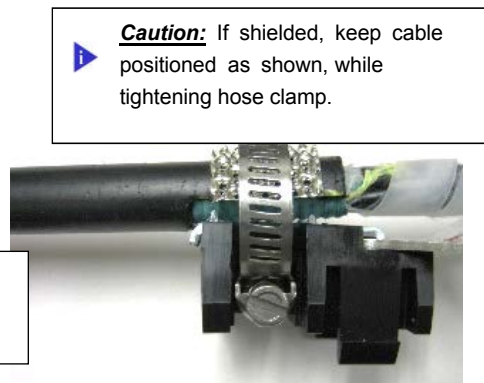

Photo #250

9.3.6 Return to Cable Preparation **Section 9.1.9.**

## 9.4 FIBER ORGANIZING/STORAGE, ROUTING AND SPLICING

### 9.4.1 INLINE STUB (cable end) configuration Ribbon Central Core Tube Shielded/Unshielded

9.4.2 Store one loop of fibers to be spliced and route ribbon to tray entry point. At tray entry point, mark ribbon 1" beyond grommet location. See photos 251-252.

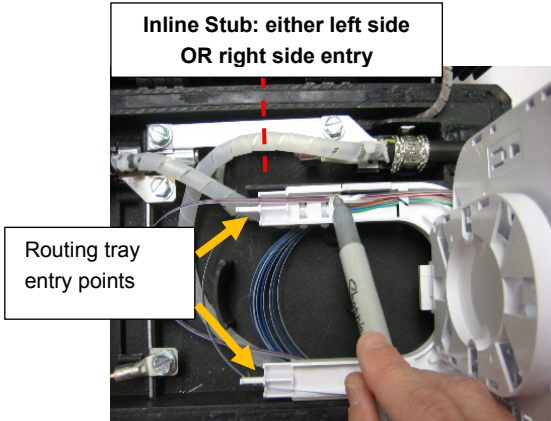

Photo #251

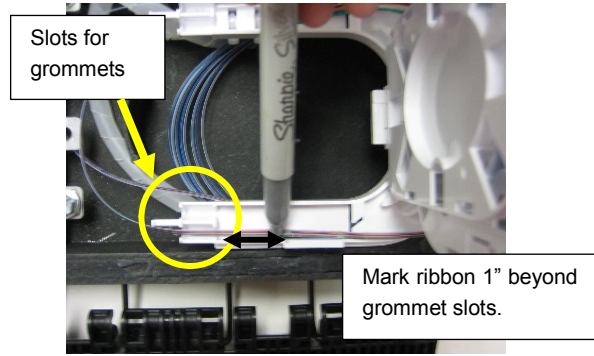

Photo #252

9.4.3 De-ribbonize fiber from mark to end of fiber.

9.4.4 Install ribbon grommet onto ribbon 1" before de-ribbonize point. Install grommets onto routing tray and secure with cable tie. See photos 253-255A.

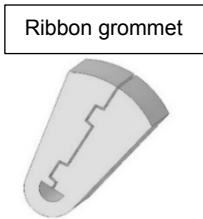

Photo #253

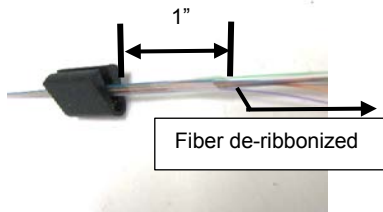

Photo #254

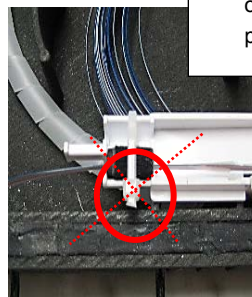

Photo # 255

**Caution:** Secure with cable tie so that it is oriented as shown in photo # 255A

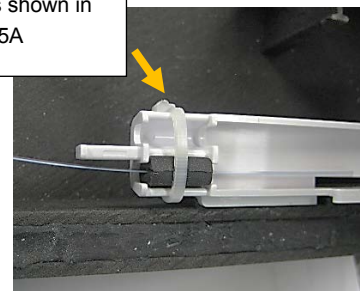

Photo # 255A

9.4.5 Route fibers that will not be spliced onto Feed Thru tray. See photo 256.

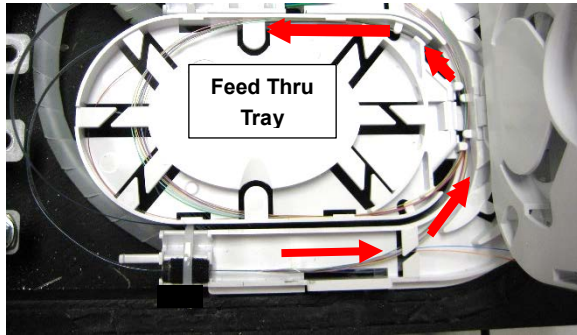

Photo #256

9.4.6 Route fibers to be spliced to top splice tray. See photos 257-259.

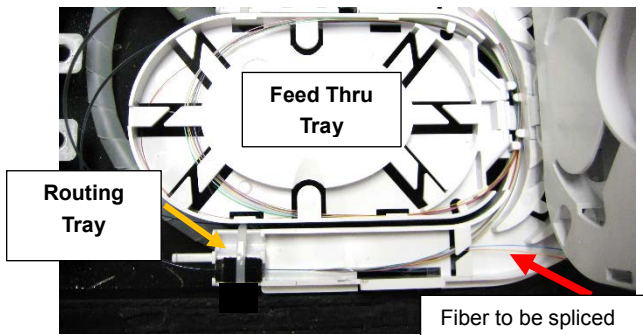

Photo #257

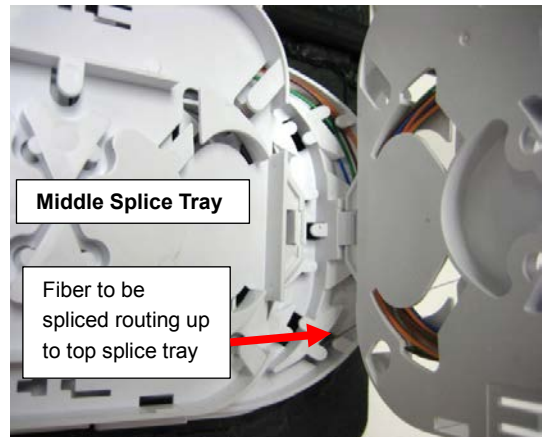

Photo #258

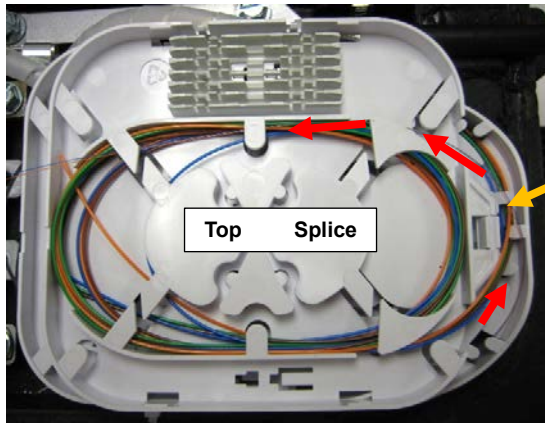

Photo #259

Fiber to be spliced routing up to top splice tray

**Caution:** SMOUVS **must** be centered when placed in the holders.

9.4.7 Splice per standard practice. Replace dust cover on tray after splicing.

## 9.5 CLOSING / SECURING CLOSURE

9.5.1 Apply optional routing label inside lid or on tray cover.

9.5.2 Install port plugs into all unused ports and ground port if no ground wire. See photo 260.

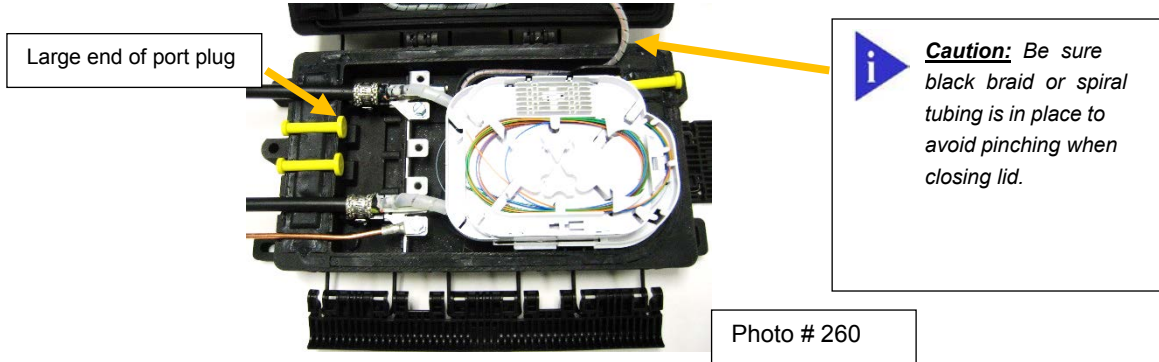

9.5.3 Close lid. Ensure all port plugs, ground wire (if present) and cables are properly aligned.

Snap right side hinge, left side hinge, then top hinge. Hinges can be closed using screwdriver or by hand. See photos 261-263.

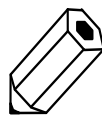
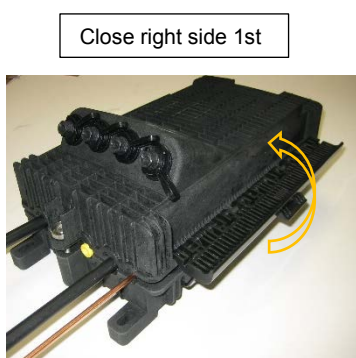

**Note:** To assist in closing the right side latch, the top can be pressed closed and the security screw can be started to hold the top closed. Then, the right side latch can be closed.

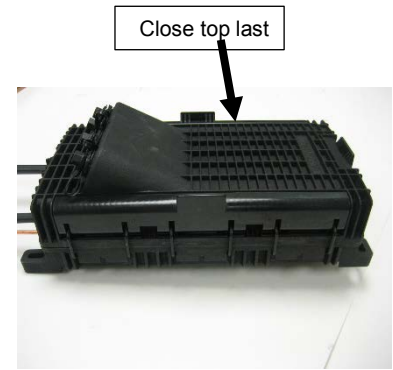

9.5.4 Tighten security bolt. See photo 264.

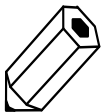

**Note:** Tighten the security bolt with a torque limiting tool, like a type 216C can wrench (shown) or 25 in.-lbs. maximum

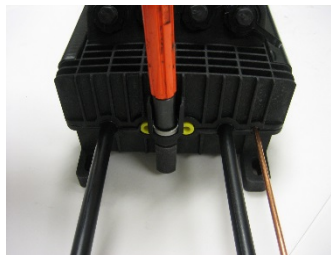

### 9.6 MOUNTING CLOSURE (PEDESTAL, STRAND & POLE MOUNT)

9.6.1 For pedestal mounting, assemble mounting bracket(s) to back of housing. Assemble to plate or rod.  
See photos 36 A-D



Photos 36 A-D

9.6.2 For strand mounting, assemble strand clamps or supplementary mounting brackets to back of housing.  
Assemble to line. See photos 36 E – F.

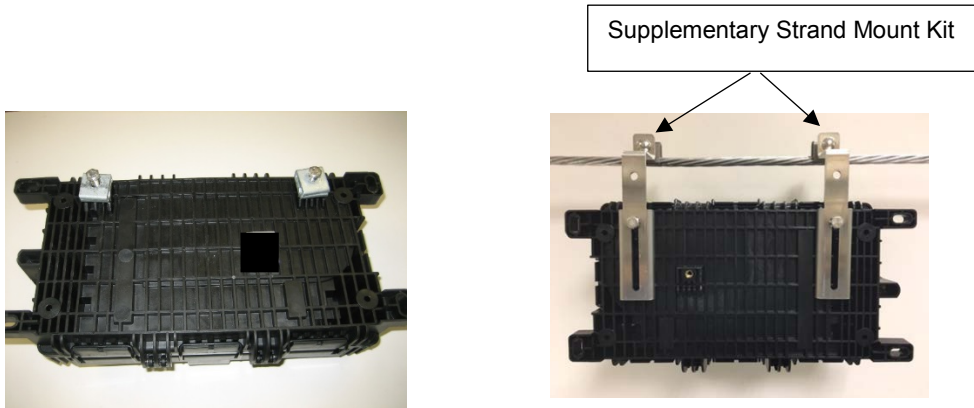

Photos 36 E- F

9.6.3 For pole mounting, assemble supplementary mounting brackets to back of housing and assemble to pole.  
See photo 37.

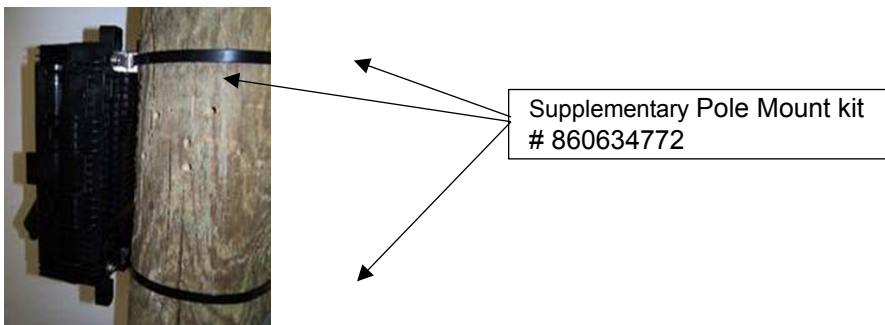

Photo 37



# Chapter 10. Butt Stub – Ribbon Central Core Tube Shielded/Unshielded

## 10.0 CABLE PREPARATION

### 10.1 Butt Stub (cable end) configuration

10.1.1 Preparation of Inline stub configuration ribbon central core tube, remove 55" of outer sheath from end of cable. See Figure 13.

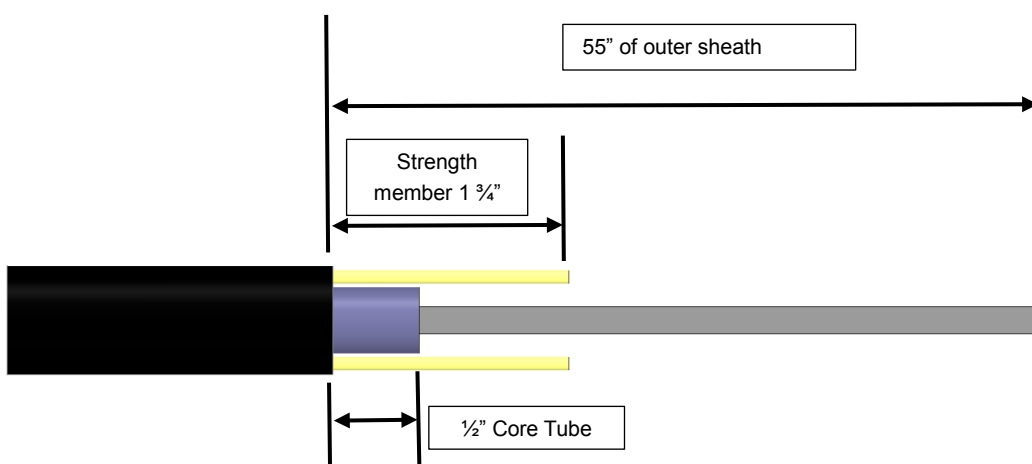

Figure 13

10.1.2 Cut strength member(s) 1 3/4" from end of sheath opening. See Figure 13.

10.1.3 Remove core tube from ribbon leaving 1/2" core tube, measured from the cable sheath openings. See Figure 13.

10.1.4 Cut one 1/2" long piece of black felt tape and wrap around core tube. See photos 267-269.

 **Note:** Steel strength members may be temporarily bent apart to aid in application of tape. See photos 267-269.



Photo # 267



Photo #268

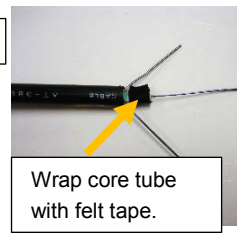



Photo #269



10.1.5 Cut 1 piece of spiral wrap 10" in length.

10.1.6 Wrap spiral wrap around ribbon so that it wraps around the 1/2" core tube. Secure with cable tie.  
See photos 270-272.

 **Note:** Straighten steel strength members back into original position.

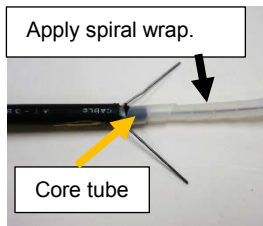

Photo # 270

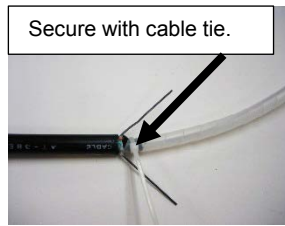

Photo #271

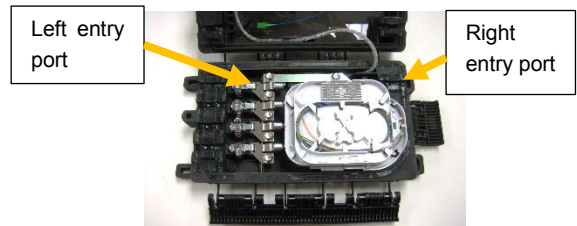

Photo # 272

10.1.7 If cable is shielded and to be grounded, proceed to **Section 10.2**, Cable and External Grounding.

10.1.8 Proceed to **Section 10.3**, Cable Retention.

10.1.9 Snap cable retention assembly into the appropriate location. Secure with bolts if grounded.  
See photos 273-275.

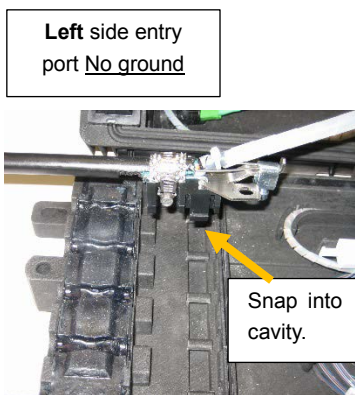

Photo #273

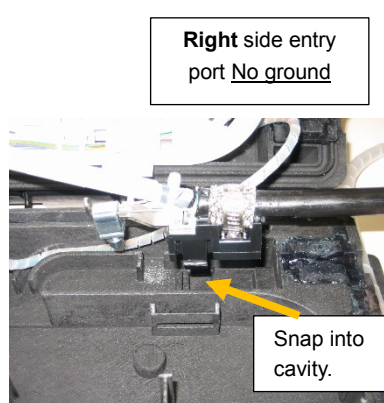

Photo #274

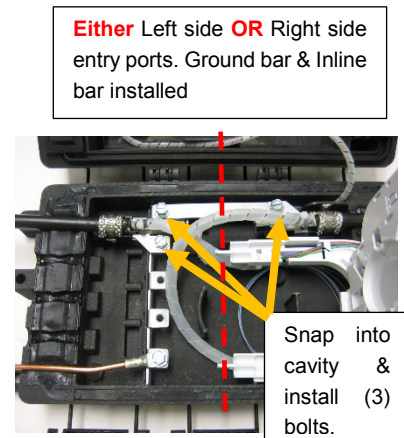
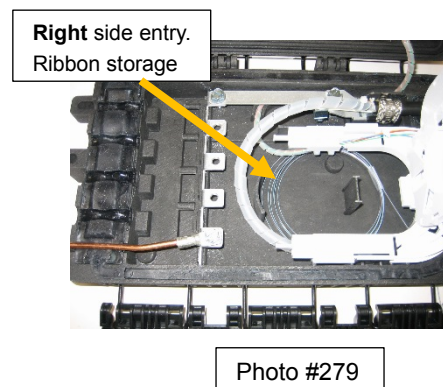
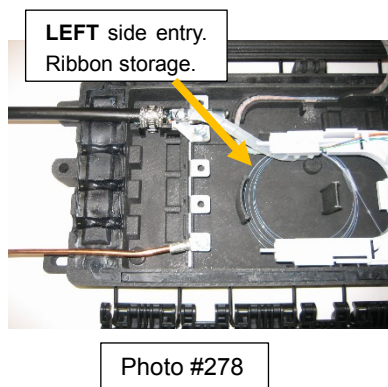
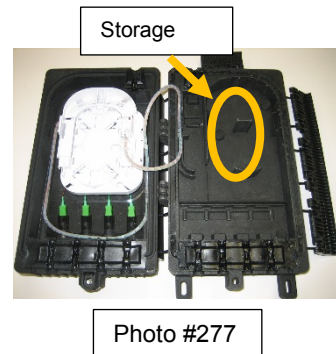
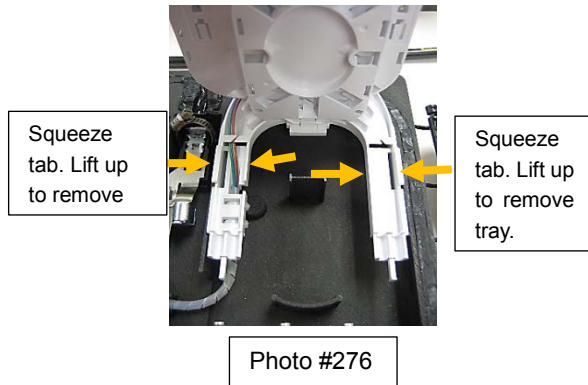

Photo #275

**Either** Left side **OR** Right side entry ports. Ground bar & Inline bar installed

10.1.10 Remove ribbon containing fiber(s) to be spliced from fiber stack.

10.1.11 If ribbons are not to be spliced, route to storage area. Tray stack may be removed for easier access to storage. See photos 276- 279.



10.1.12 Proceed to **Section 10.4**, for Fiber Routing and Splicing.

## 10.2 CABLE & EXTERNAL GROUNDING

10.2.1 For cable with shielding, remove a section of the outer sheath 180° around the cable by 1.0" in length measured from the end of the outer sheath in order to expose cable shielding. See photo 280.

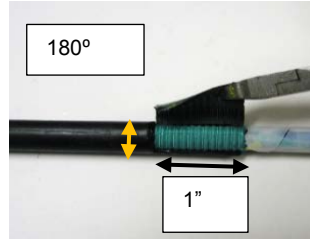

Photo #280



**NOTE:** Exposed shielding will be bonded to the cable retention bracket and ground bar.

10.2.2 For grounding, press ground bar into slot in closure. If using Inline configuration, install inline ground bar and secure with bolt. See photo 281.

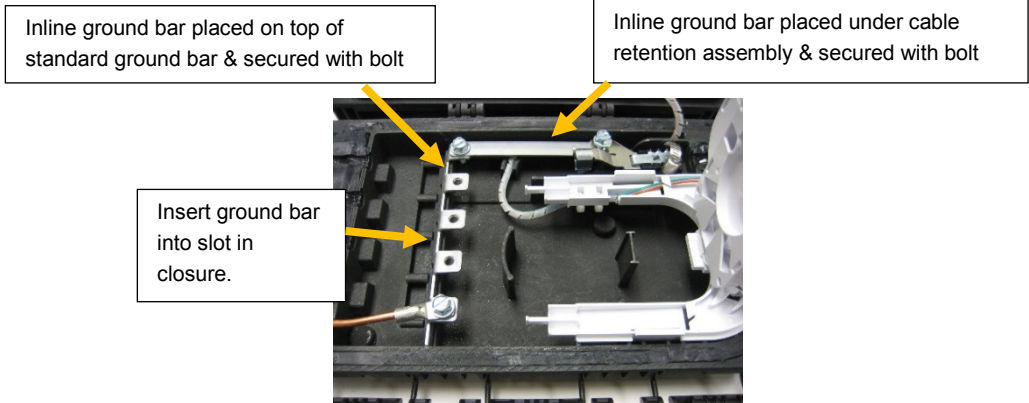

Photo # 281

10.2.3 External ground connection is to be placed in designated location. The ground wire is to be secured using the same bolt that is used to secure the cable retention assembly. See photo 282.

▶ **Caution:** Do not use braided or stranded ground wire when installing a ground through a port on the Mini-OTE 300 closure. A solid ground wire is required to prevent a leak path and make a proper seal.

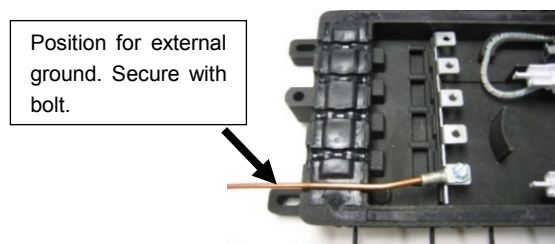

Photo # 282

## 10.3 CABLE RETENTION

10.3.1 Open hose clamp on cable retention assembly. Place cable retention assembly around cable. If cable is shielded and to be grounded, orient the sheath opening, which exposes the shielding, toward the base of retention clamp. See photos 283-284.

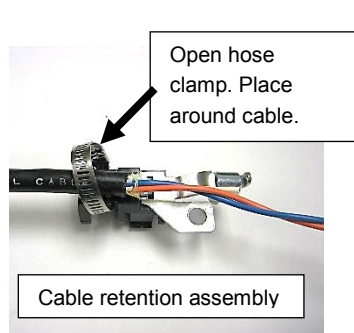

Photo # 283

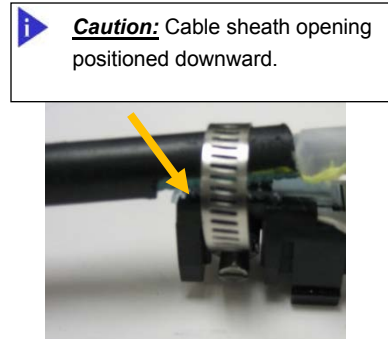

Photo # 284

10.3.2 Insert strength member(s) into lug and hand tighten screw with the tool provided. See photo 285.

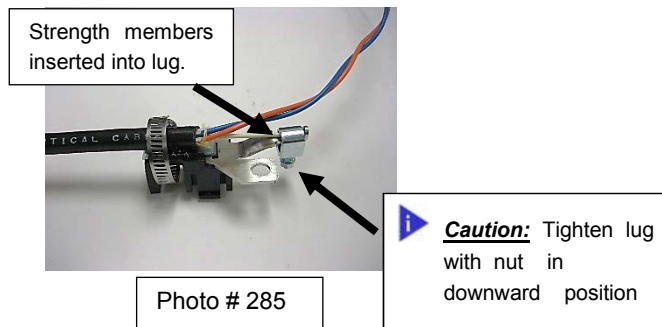

Photo # 285

10.3.3 Cut perforated foil into 3 pieces (note orientation) and form over cable. If Flat Drop, wrap around drop. See photos 286-288.

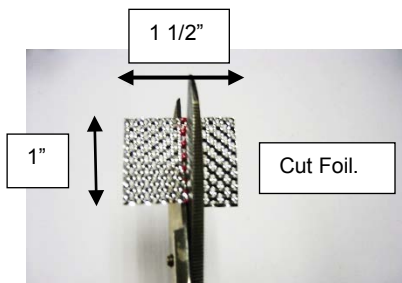

Photo # 286

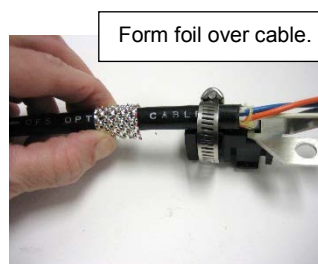

Photo # 287



Photo # 288

10.3.4 Place 1 pc of perforated foil between the hose clamp and outer sheath of cable. Tighten hose clamp being sure to keep the screw head positioned under the cable retention assembly in order to avoid interference when installing closure. See photos 289-290.

Place foil under hose clamp

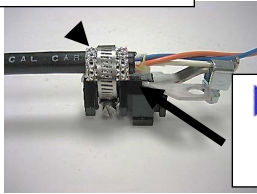

Photo # 289

**Caution:** Tighten screw, keep screw in contained area.

**Caution:** If shielded, keep cable positioned as shown, while tightening hose clamp.



Photo # 290

10.3.5 Return to Cable Preparation **Section 10.1.9.**

## 10.4 FIBER ORGANIZING/STORAGE, ROUTING AND SPLICING

10.4.1 BUTT STUBB (cable end) configuration Ribbon Central Core Tube Shielded/Unshielded

10.4.2 Place one loop of ribbon fiber to be spliced in storage area

10.4.3 Route ribbon to tray entry points and mark ribbon 1" beyond grommet locations. De-ribbonize fiber between marks. See photos 291-292.

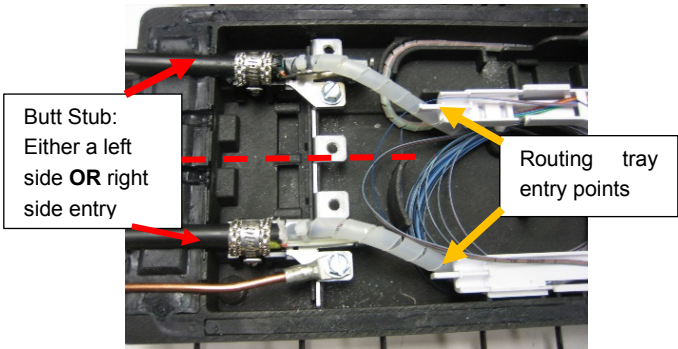

Photo # 291

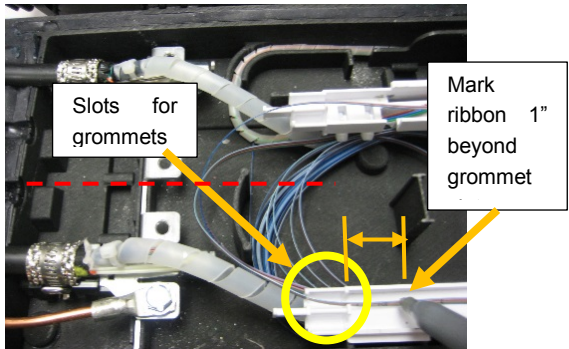

Photo # 292

10.4.4 Install ribbon grommets onto ribbon 1" before de-ribbonize point. Install grommets onto routing tray and secure with cable tie. See photos 293-296

Ribbon grommet



Photo # 293

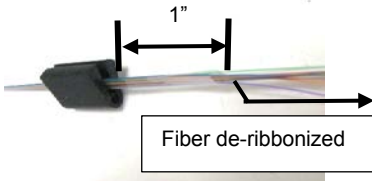

Photo # 294



Photo # 295

**Caution:** Secure with cable tie so that it is oriented as shown in photo # 296

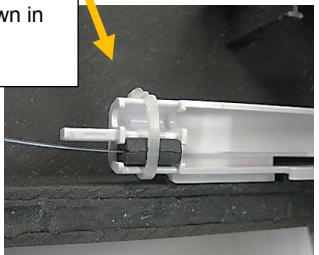

Photo # 296

10.4.5 Route express fibers and “dead to field” onto Feed Thru tray. See photo 297.

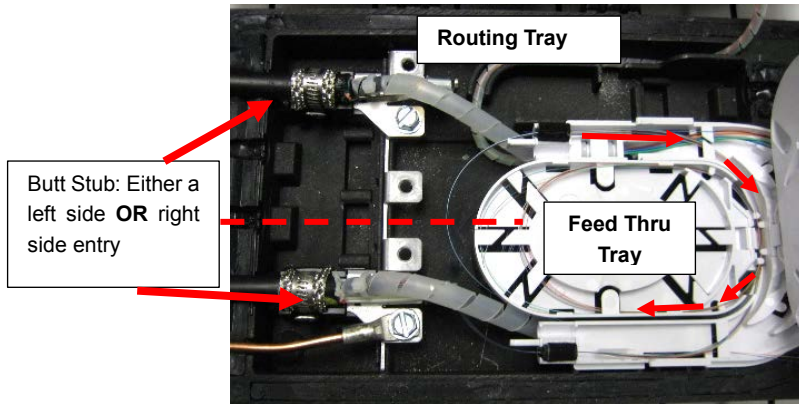

Photo # 297

10.4.6 Route fibers to be spliced to top splicing tray. See photos 298-300.

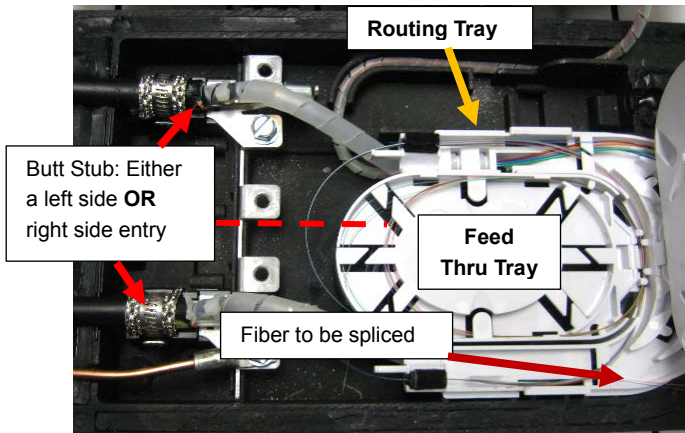

Photo # 298

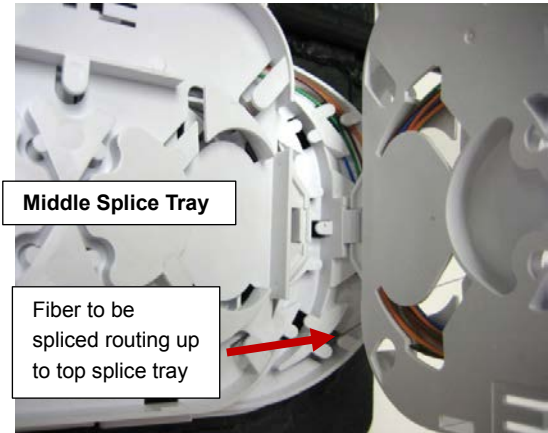

Photo # 299

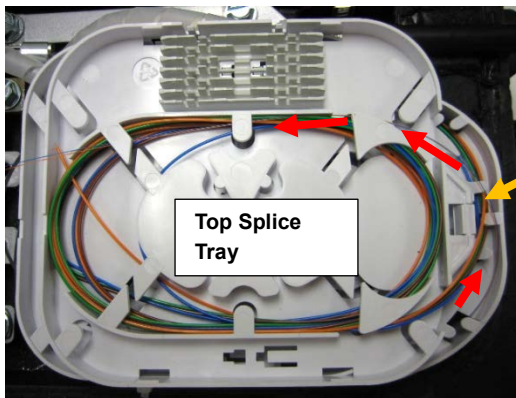

Photo # 300

Fiber to be spliced routing up to top splice tray

**Caution:** SMOUVS **must** be centered when placed in the holders.

10.4.7 Splice per standard practice. Replace dust cover on tray after splicing.

## 10.5 CLOSING / SECURING CLOSURE

10.5.1 Apply optional routing label inside lid or on tray cover.

10.5.2 Install port plugs into all unused ports. See photo 301.

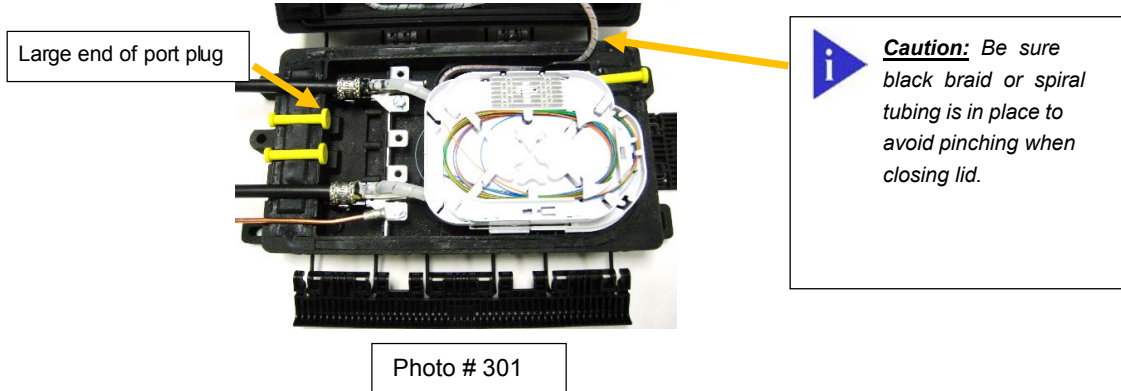

10.5.3 Close lid. Ensure all port plugs, ground wire (if present) and cables are properly aligned.

Snap right side hinge, left side hinge, then top hinge. Hinges can be closed using **screwdriver** or **by hand**. See photos 302-304.



10.5.4 Tighten security bolt. See photo 305.

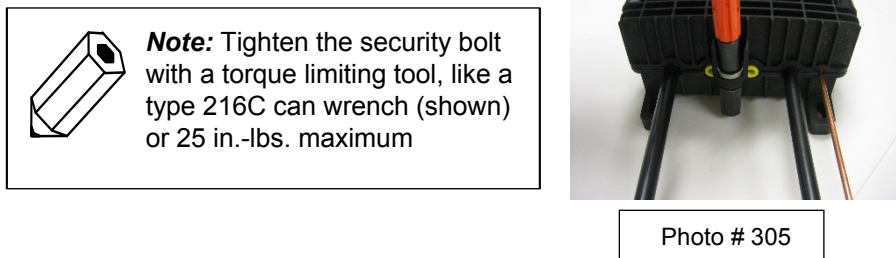

### 10.6 MOUNTING CLOSURE (PEDESTAL, STRAND & POLE MOUNT)

10.6.1 For pedestal mounting, assemble mounting bracket(s) to back of housing. Assemble to plate or rod.  
See photos 36 A-D

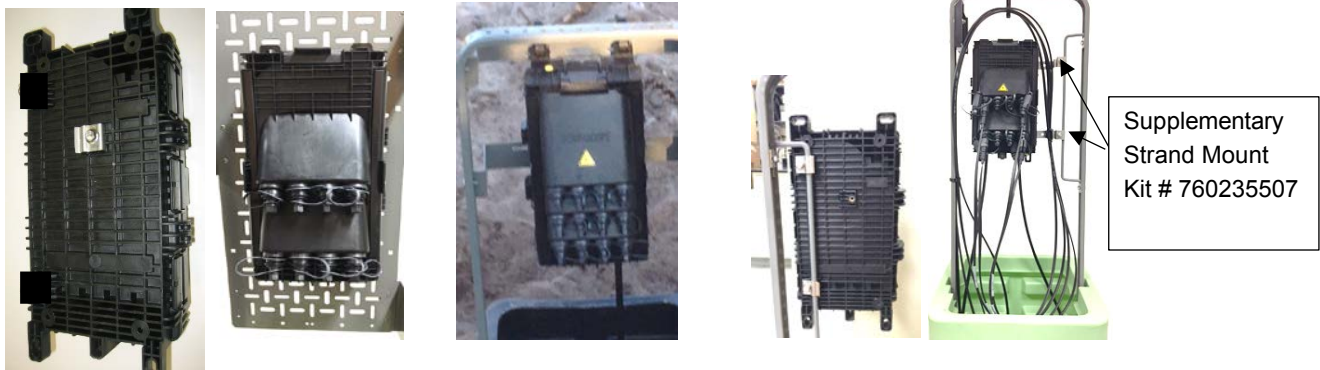

Photos 36 A-D

10.6.2 For strand mounting, assemble strand clamps or supplementary mounting brackets to back of housing.  
Assemble to line. See photos 36 E – F.

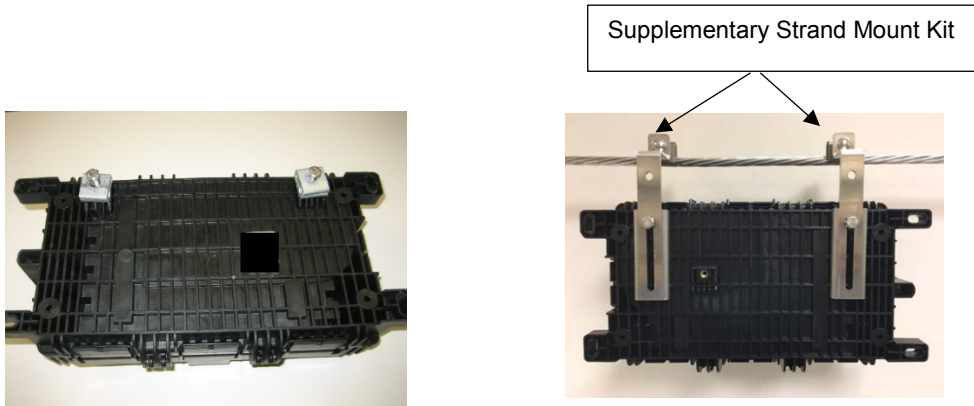

Photos 36 E- F

10.6.3 For pole mounting, assemble supplementary mounting brackets to back of housing and assemble to pole.  
See photo 37.

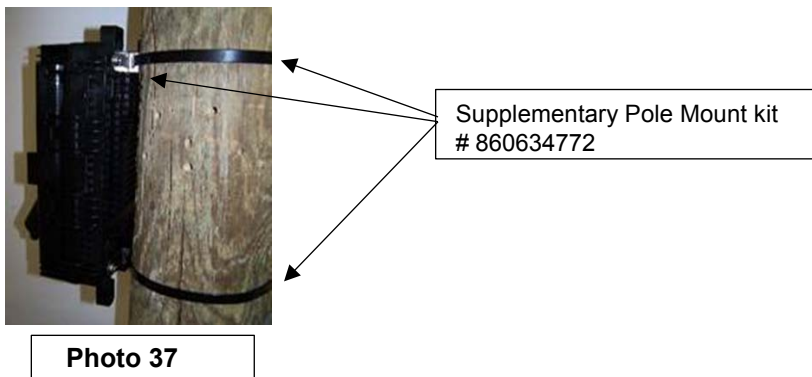

Photo 37



# Chapter 11. Installation of Hardened Connectors and Adapters

## 11.0 USING HARDENED CONNECTORS AND ADAPTERS

11.1.0 Hardened connectors and adapters provide sealed environmental protection for the subscriber drop cable connector and the SC adapter mounted within the Mini-OTE optical port. The following sections provide a description of the connector and adapter components and provide instructions for connecting or disconnecting the drop cable to/ from the optical ports.

11.2.0 The basic components of the drop cable connector are shown in Figure 14. The dust cap threads onto the connector coupling nut. A pair of O-rings on the connector body provide a tight seal when the dust cap is in place. A pulling eye is provided in the end of the dust cap for pulling the drop cable through conduit.

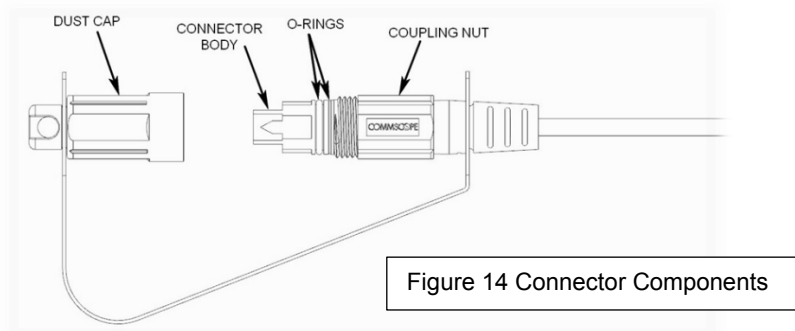

11.3.0 The basic components of the Mini-OTE optical port hardened adapter are identified below in Figure 15. The dust cap threads into the adapter housing. An O-ring on the dust cap provides a tight seal when the dust cap is in place. The 216C key tool is required to remove the dust cap.

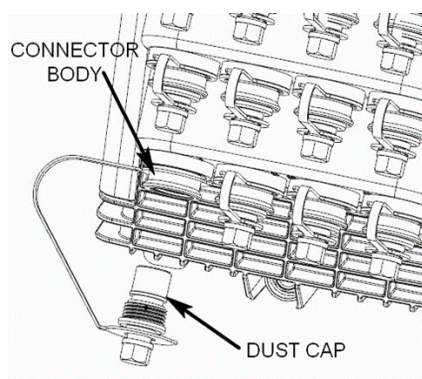

## 11.1 CONNECTING DROP CABLE TO MINI-OTE OPTICAL PORT

 **Danger:** Exposure to laser radiation can seriously damage the retina of the eye. Do not look into the ends of any optical fiber. Do not assume the laser power is turned-off or that the fiber is disconnected at the other end. Use the following procedure to connect a drop cable to an optical port on the Mini-OTE enclosure:

11.1.1 Unscrew the dust cap from the drop cable connector (see Figure 17).

11.1.2 Inspect the drop cable connector O-rings for dryness and apply O-ring lubricant (MST-ACC-LUBE1) to each O-ring if dry.

 **Note:** The connector O-rings are pre lubricated by the factory and should not require additional lubrication for the initial assembly.

11.1.3 Use the 216C key tool (accessory) to unscrew the dust cap (see Figure 15) from the Mini-OTE optical port.

11.1.4 Clean both the optical port adapter and the drop cable connector (requires accessory kit FHD-ACC-CLNKIT1) as specified in ADCP-96-067.

11.1.5 Align the drop cable connector with the optical port as shown in Figure 16. The pointer on the drop cable connector should line up with the notch on the optical port.

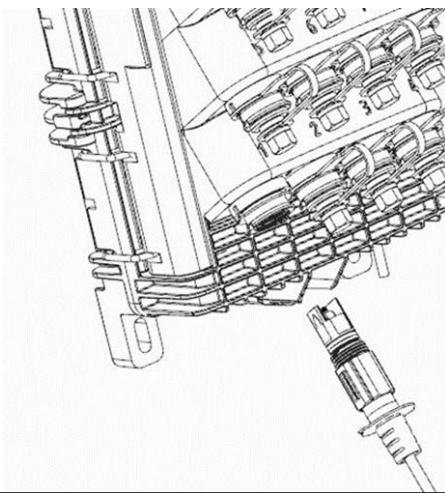



Figure 16 Connecting Drop Cable to Mini-OTE Optical Port

11.1.6 Insert the drop cable connector into the optical port. If the drop cable connector does not insert all the way to the bottom of the port, rotate drop cable connector slightly to either side until it slides freely into place.

11.1.7 Thread the drop cable connector coupling nut into the optical port and tighten coupling nut until finger tight.

11.1.8 Inspect the optical port dust cap O-ring (see Figure 14) for dryness and apply O-ring lubricant to the O-ring if dry (MST-ACC-LUBE1). Refer to O-Ring Lubrication for the procedure.

 **Note:** The optical port dust cap O-ring is pre lubricated by the factory and should not require additional lubrication for the initial assembly.

11.1.9 Thread the optical port dust cap into the drop cable dust cap as shown in Figure 17 and then tighten both dust caps finger tight. This ensures that both dust caps will stay clean when not in use.

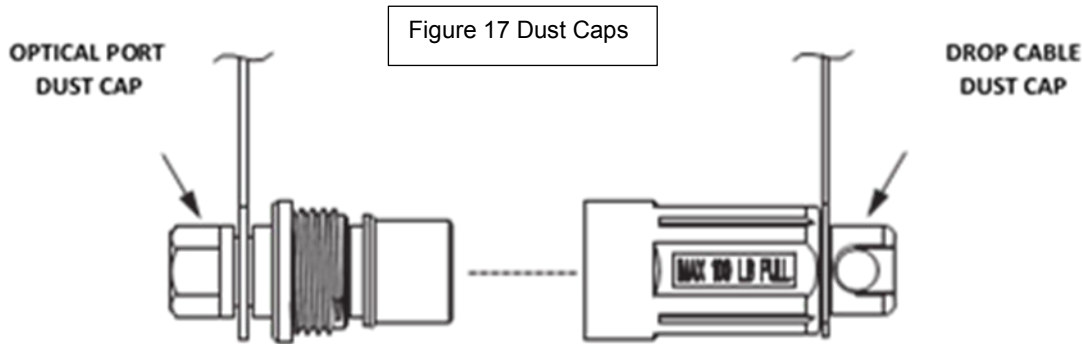

## 11.2.0 DISCONNECTING DROP CABLE FROM MINI-OTE PORT

**Danger:** Exposure to laser radiation can seriously damage the retina of the eye. Do not look into the ends of any optical fiber. Do not assume the laser power is turned-off or that the fiber is disconnected at the other end.

11.2.1 Unscrew the optical port dust cap from the drop cable dust cap (see Figure 14).

11.2.2 Unscrew the drop cable connector coupling nut from the optical port (see Figure 15).

11.2.3 Inspect the optical port dust cap O-ring for dryness and apply O-ring lubricant (MST-ACC-LUBE1) to the O-ring if dry. Refer to **O-Ring Lubrication** for the required procedure.

11.2.4 Thread the optical port dust cap into the optical port and tighten using the 216C key tool (see Figure 16).

11.2.5 Inspect the drop cable connector O-rings for dryness and apply O-ring lubricant (MST-ACC-LUBE1) to each O-ring if dry. Refer to **O-Ring Lubrication** for the required procedure.

11.2.6 Thread the drop cable dust cap onto the drop cable connector coupling nut and tighten until finger tight (see Figure 17).

## 11.3.0 MAINTENANCE OF MINI-OTE 300 TERMINALS

11.3.1 Maintenance for the Mini-OTE terminal is limited to cleaning the hardened adapters as needed to maintain optimal performance, lubricating O-rings that may become dry, or replacing a damaged optical connector.

## 11.4.0 DROP CABLE CONNECTOR CLEANING PROCEDURE

**Cleaning kit (FHD-ACC-CLNKIT1) is required for this procedure. Use the following procedure to clean the drop cable connector:**

11.4.1 Unscrew the drop cable connector dust cap from the end of the drop cable connector.

11.4.2 Examine the end of the drop cable connector and determine which is the high side and which is the low side of the connector end-face as shown in Figure 18.

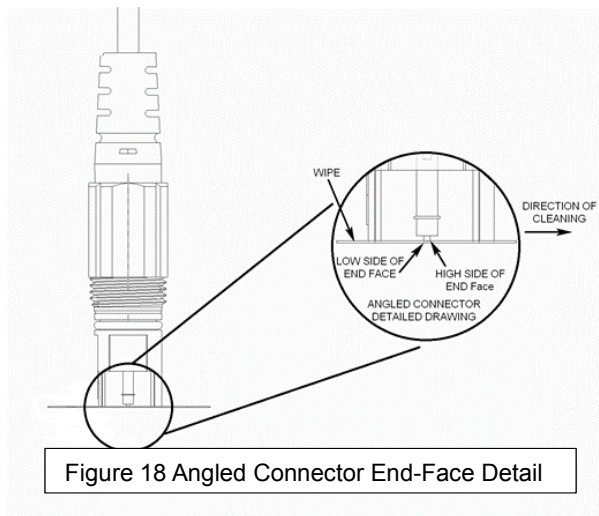
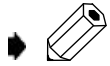

Figure 18 Angled Connector End-Face Detail

11.4.3 Locate the cleaning tape cassette that is provided with the cleaning kit.

11.4.4 Open the tape shutter by squeezing the lever on the underside of the cassette and then keep the shutter open by continuing to squeeze the lever.

11.4.5 Hold the end-face of the drop cable connector perpendicular to the cleaning tape and with the high side of the connector pointing in the direction of cleaning as shown in Figure 19.



**Note:** The drop cable connector uses angled SC type connectors. Make sure the high side of the connector end-face is pointing in the direction of the cleaning motion.

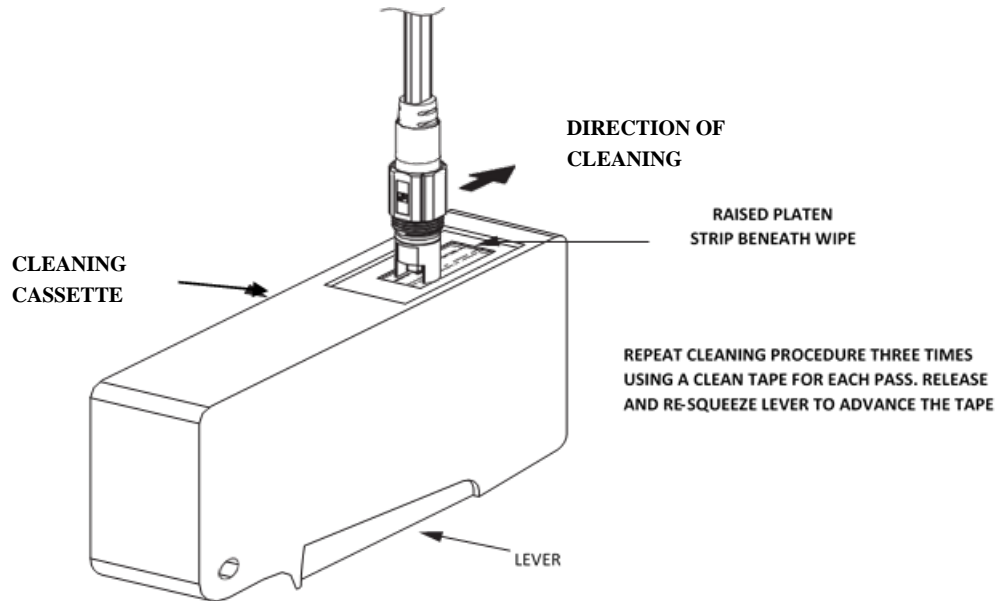

Figure 19 Cleaning Drop Cable Connector

- 11.4.6 With light pressure, slide the connector end-face once across the tape in the direction shown using a smooth linear motion. Do not press too hard and do not repeat the cleaning motion with the same tape.
- 11.4.7 Release the lever on the underside of the cassette to close the tape shutter.
- 11.4.8 Repeat steps 11.4.3 through 11.4.6 until the connector has been cleaned three times.
- 11.4.9 When the connector is clean, reinstall the drop cable dust cap and tighten until finger tight.

### 11.5.0 MINI-OTE ADAPTER/CONNECTOR CLEANING PROCEDURE

Cleaning kit (FHD-ACC-CLNKIT1) is required for this procedure. Use the following procedure to clean the Mini OTE optical port adapters and the internal connectors:

- 11.5.1 Using a 216C key tool, unscrew the optical port dust cap from the optical port adapter.
- 11.5.2 Locate the dry swabs that are provided with the connector/adapter cleaning kit.
- 11.5.3 Insert a dry swab into the adapter as shown in Figure 20.

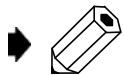

**Note:** Do not apply alcohol to the swab or the adapter.

- 11.5.4 While applying light pressure against the connector end-face, rotate the dry swab 360° three times.
- 11.5.5 Dispose of the dry swab after use.
- 11.5.6 When the connector end-face and adapter ferrule are clean, reinstall the optical port dust cap and tighten using the 216C key tool.

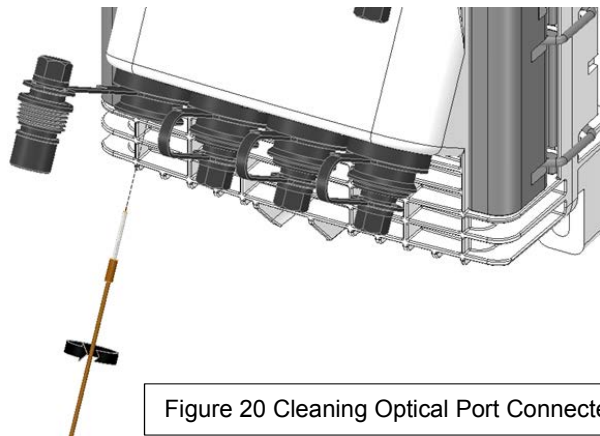

Figure 20 Cleaning Optical Port Connector and Adapter

### 11.6.0 O-Ring Lubrication

- 11.6.1 The O-rings used on the hardened connector and on the optical port dust cap are lubricated when shipped from the factory to prevent damage during installation.
- 11.6.2 If the O-rings become excessively dry, they may require additional lubrication to prevent damage. Remove the O-rings from the connector or dust cap and apply a small amount of lubricant directly to each ring. Then reinstall the O-rings on the connector or dust cap. Apply only the recommended O-ring lubricant (MST-ACC-LUBE1).

[www.commscope.com](http://www.commscope.com)

TECP-91-009 - Issue 4 - May 2019 I/M Mini-OTE 300 (300100118456 Rev D)

For more information or technical support, visit our Web site Support Center:

<http://www.commscope.com/SupportCenter>

© 2019 CommScope, Inc. All rights reserved.

All trademarks identified by ® or ™ are registered trademarks or trademarks, respectively, of CommScope, Inc.

This document is for planning purposes only and is not intended to modify or supplement any specifications or warranties relating to CommScope products or services.

---

Mini-OTE 300 Installation Guide

All trademarks used in this publication are CommScope registered  
2019 CommScope Inc. All rights Reserved