

## Deckel öffnen

## Opening of cover

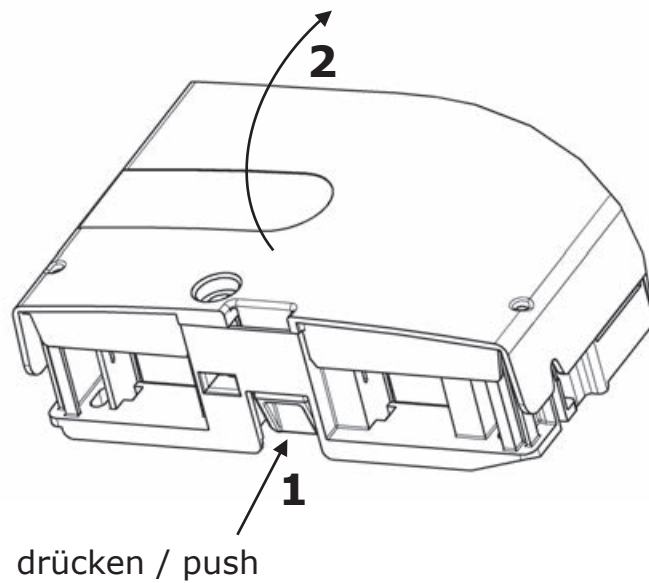

## Öffnungswinkel

## Opening angle

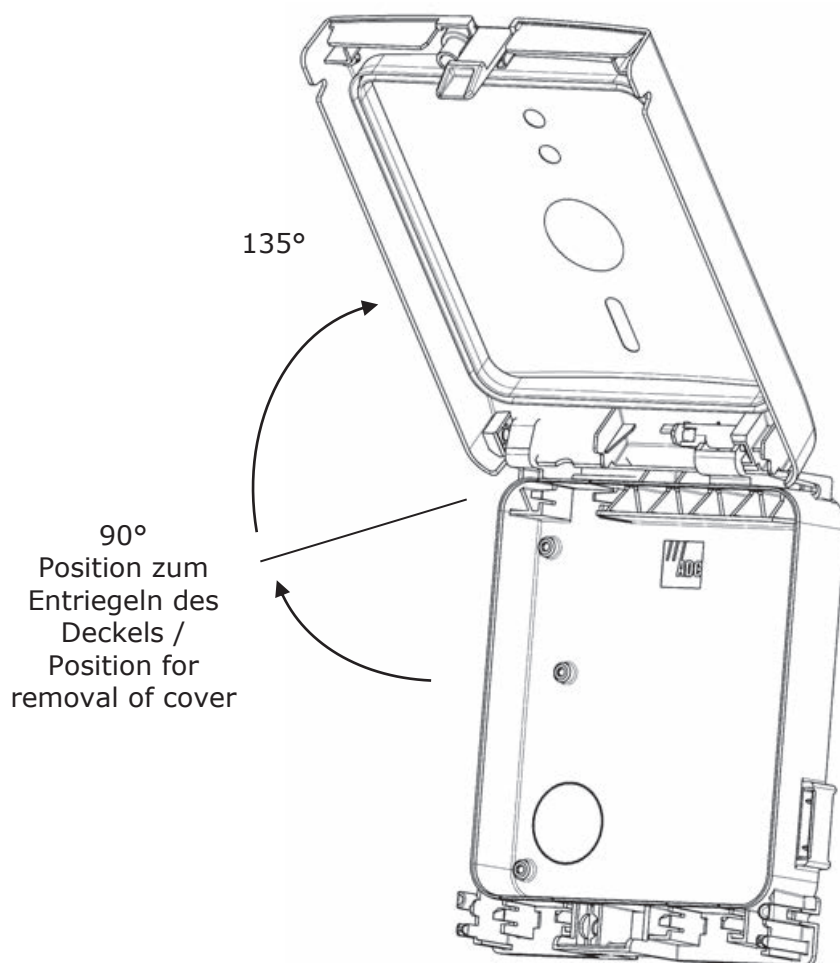

# Deckel demontieren und montieren Removal and assembly of cover

1 ; 2 → Demontage  
1' ; 2' .....→ Montage

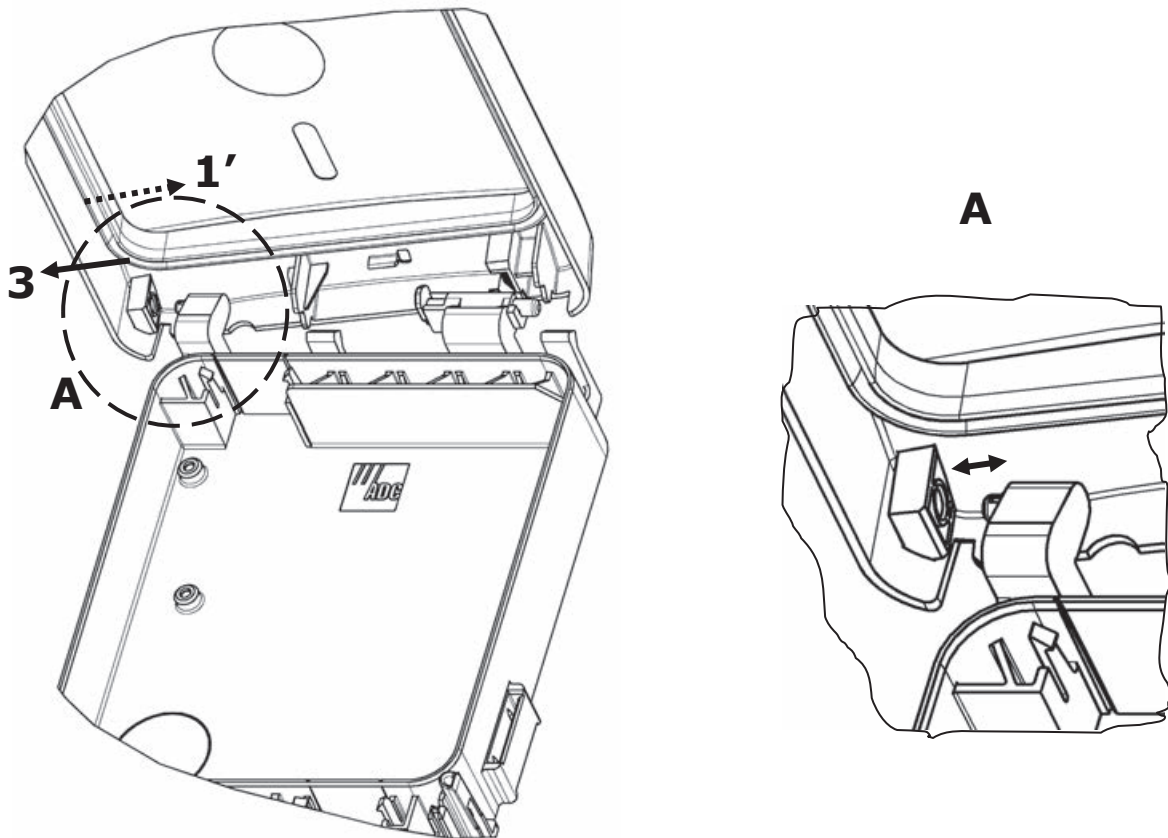
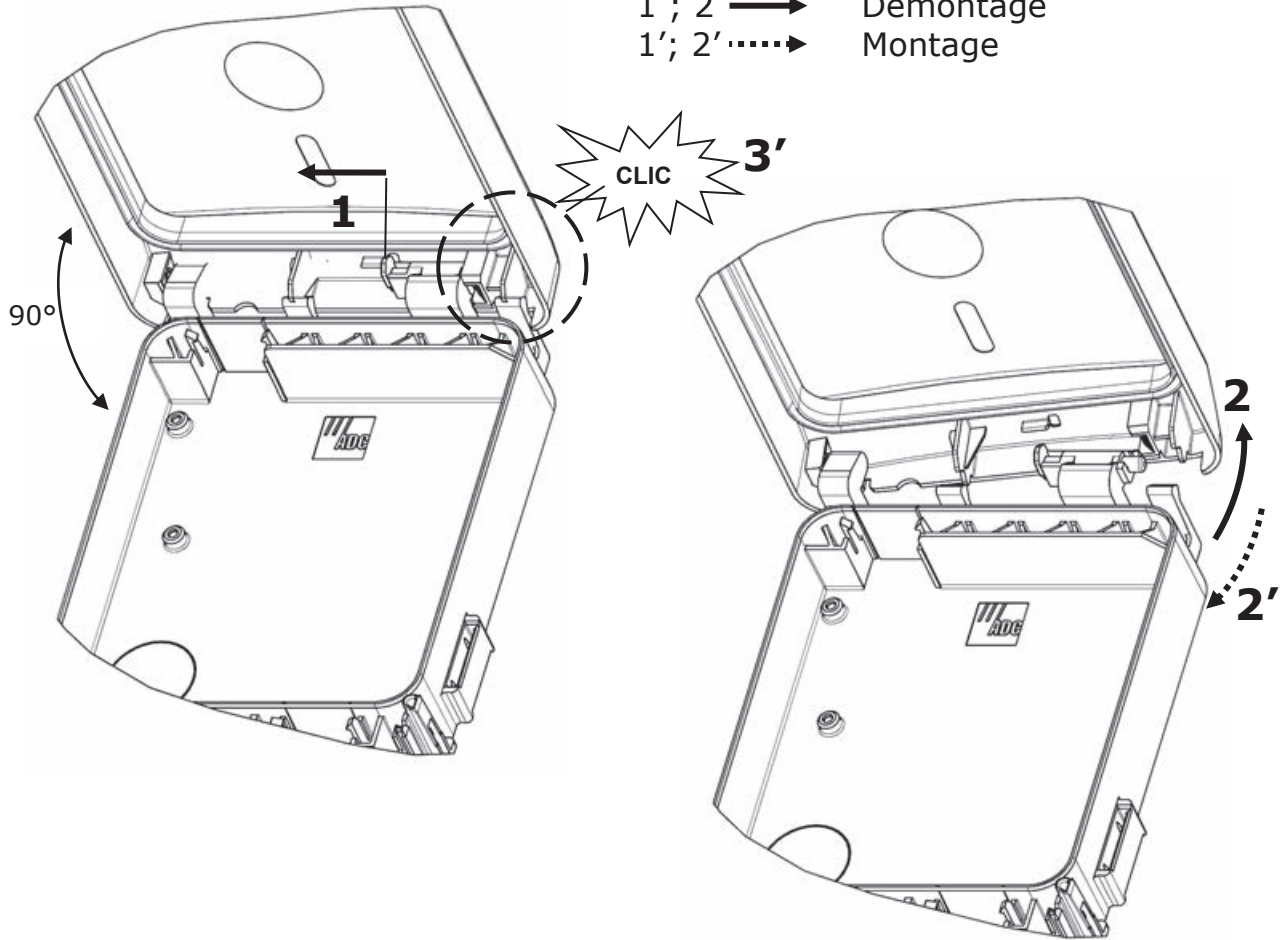

## Einbau Rillenschraube (optional)

## Assembly of Security Screw (optional)

Anzugsdrehmoment  $> 6 \text{ Nm} \leq 7 \text{ Nm}$  / starting torque  $> 6 \text{ Nm} \leq 7 \text{ Nm}$

Rillenschraube M6  
entsprechend  
TS0075/96  
Deutsche Telekom /  
Security screw M6  
according to  
TS0075/96  
German Telekom

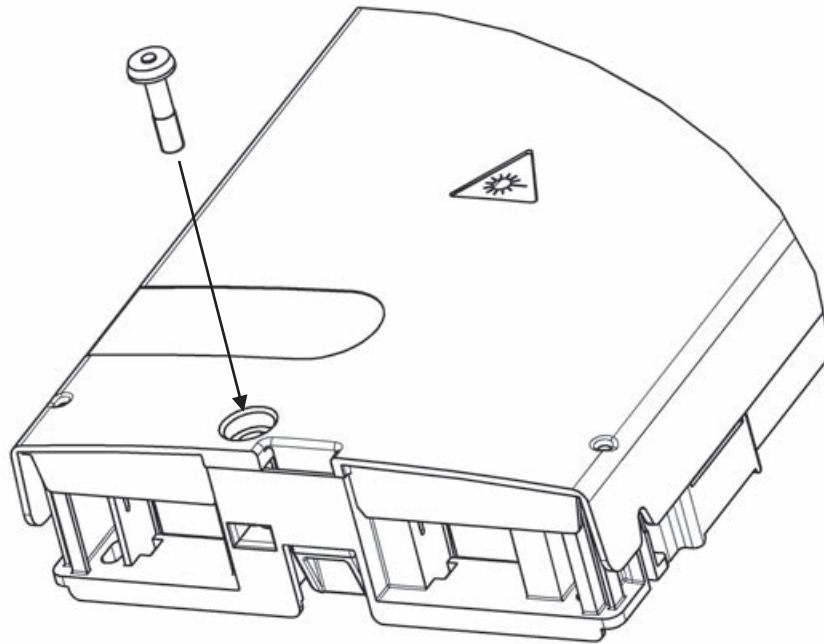

## Anbringung Plombe

## Use of wire seal

Durchführungsmöglichkeit für Draht zum Plombieren /  
Openings for wire seal

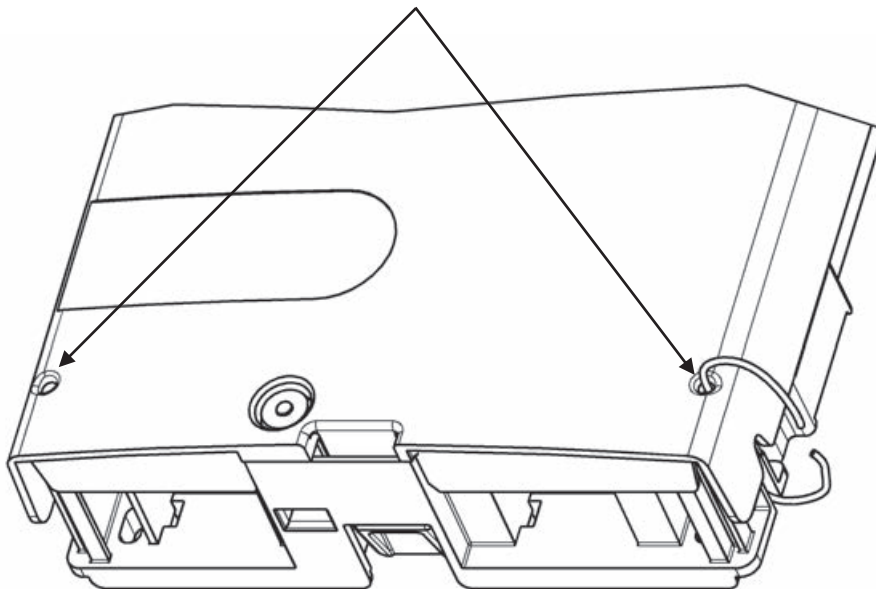

## Wandbefestigung

## Wall mounting

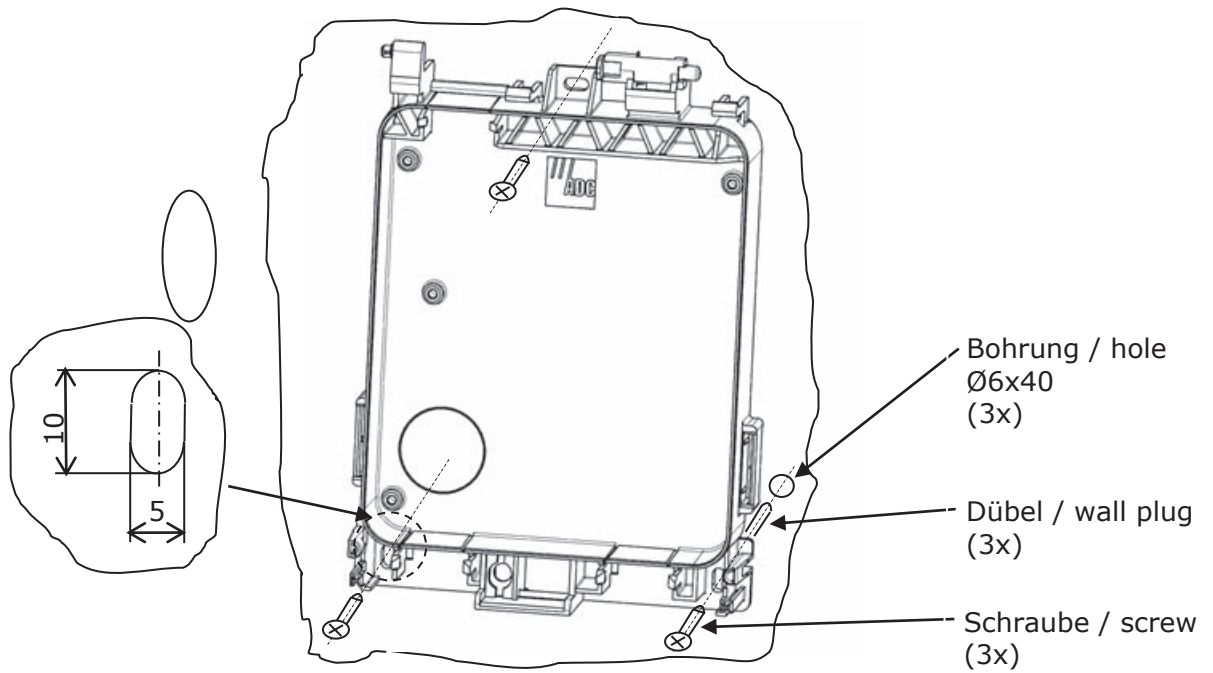

Bohrschablone (siehe Seite 10-11)

drill template (see page 10-11)

## Minimum Abstand oberhalb des Gehäuses

## Minimum clearance above the enclosure

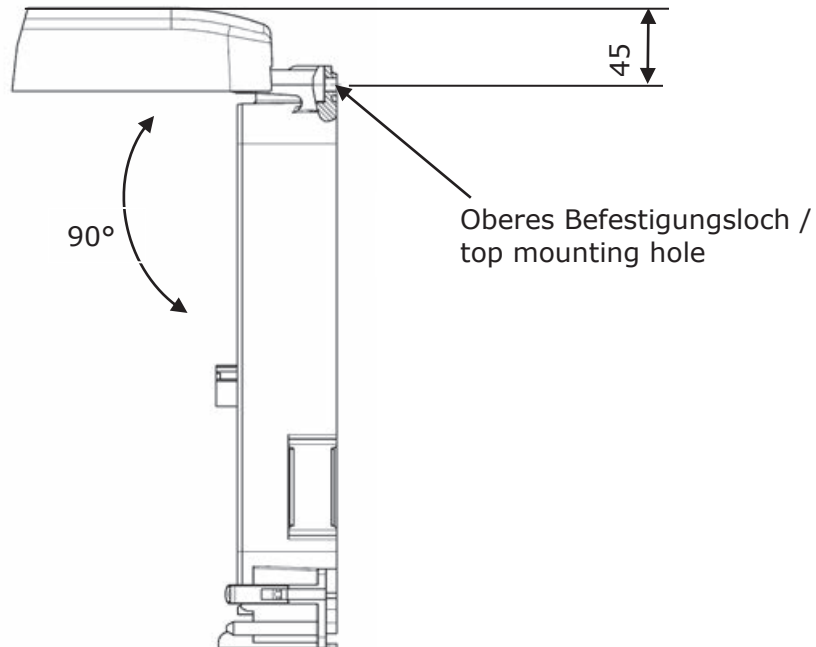

## Gehäuse anreihen (optional)

## Alignment of multiple boxes (optional)

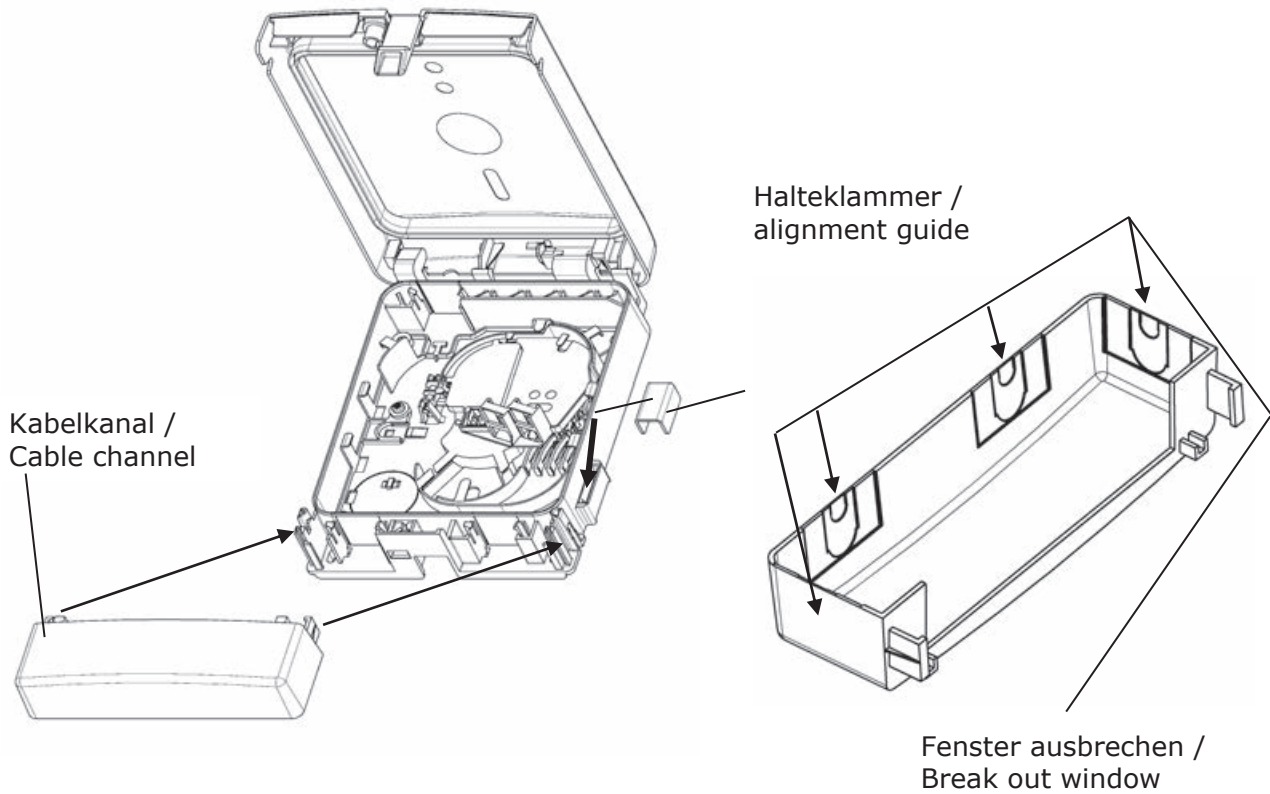
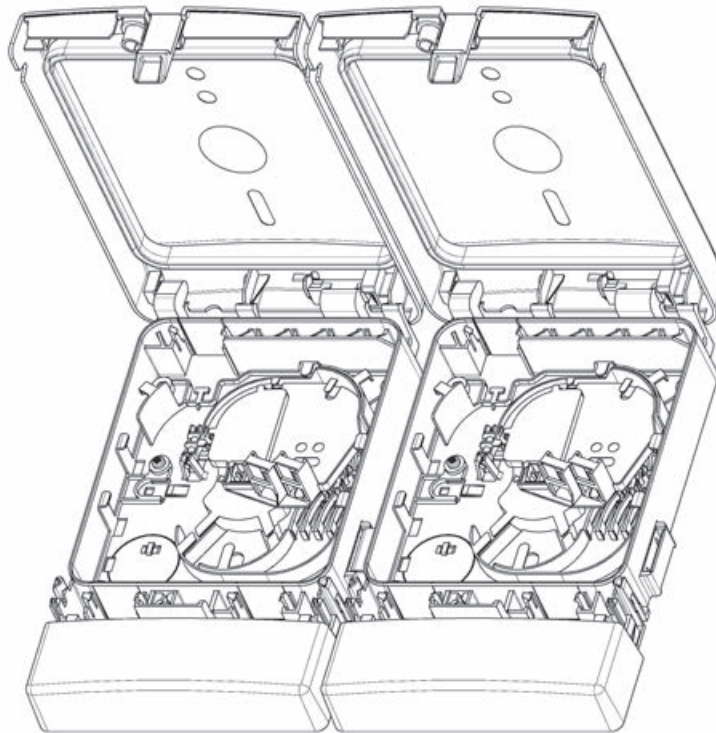

# Dichtungen

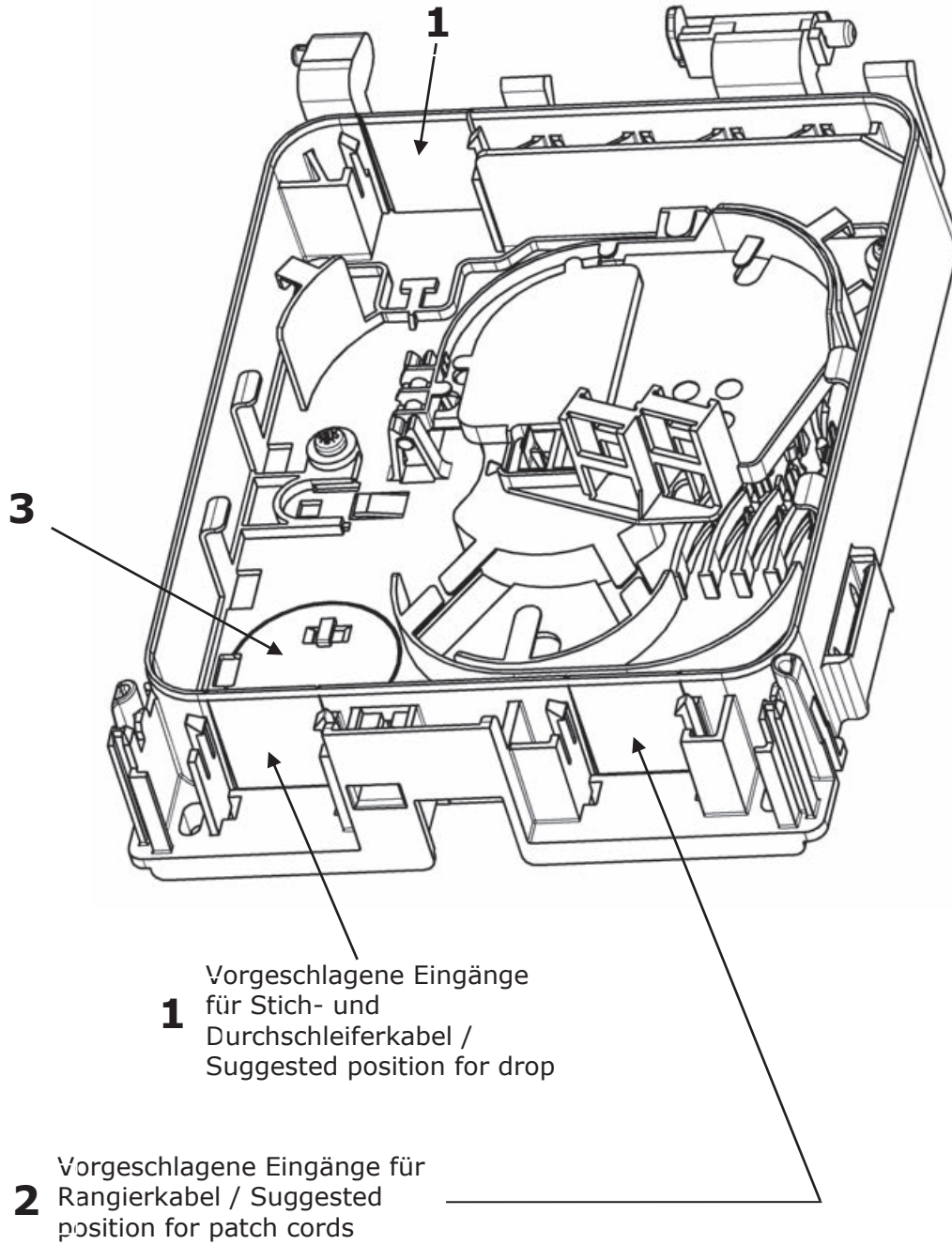

# Grommets



1	2	3

## Verfügbare Dichtungen

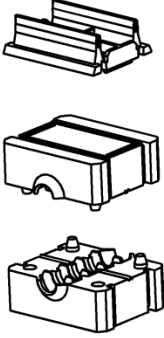
## Available grommet types

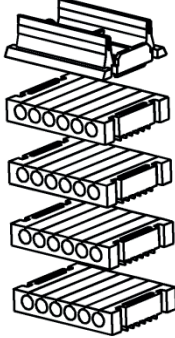
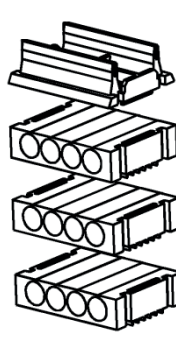
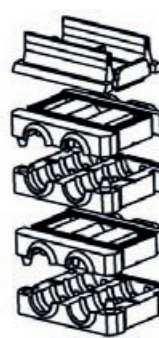
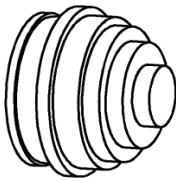
für Stich- und Durchschleiferkabel / for drop and express cables		für kleine Kabeldurchmesser und Rangierkabel / for small cable diameters and patch cords			für rückseitigen Zugang / for rear access
Ø 5-7 mm	Ø 7-12 mm	< Ø 3 mm	< Ø 5 mm	Ø 8 mm	< Ø 12 mm
MBF-ACC-GR20701-01	MBF-ACC-GR21201-01	MBF-ACC-GR20324-01	MBF-ACC-GR20512-01	MBF-ACC-GR20804-01	6541201400
GROMMET IP55 1X05-07	GROMMET IP55 1X07X12	GROMMET IP55 24X03	GROMMET IP55 12X05	GROMMET IP55 4X08	SEAL GROMMET A30/A100 BOX
					

## Kabeleingänge ausbrechen

## Open cable entries

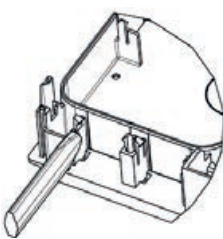
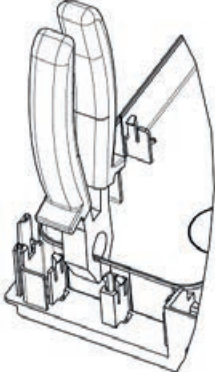
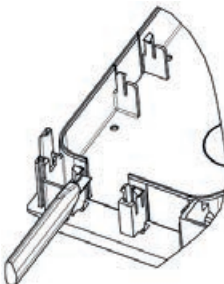
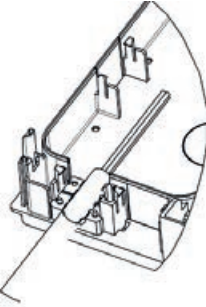
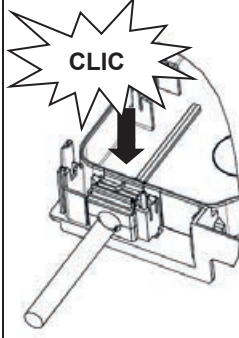
Bruchkanten einritzen / Score edges	Fenster ausbrechen / Break out window	Bruchkanten entgraten / Deburr edges	Dichtungshälfte und Kabel einlegen / Insert grommet half and cable	2. Dichtungshälfte und Deckel einsetzen / Insert 2 <sup>nd</sup> grommet half and cover
				



**Kabeldurchführungen der  
Rangierkabeldichtung vorbereiten**

**Preparation of cable entries of  
grommets for patch cords**

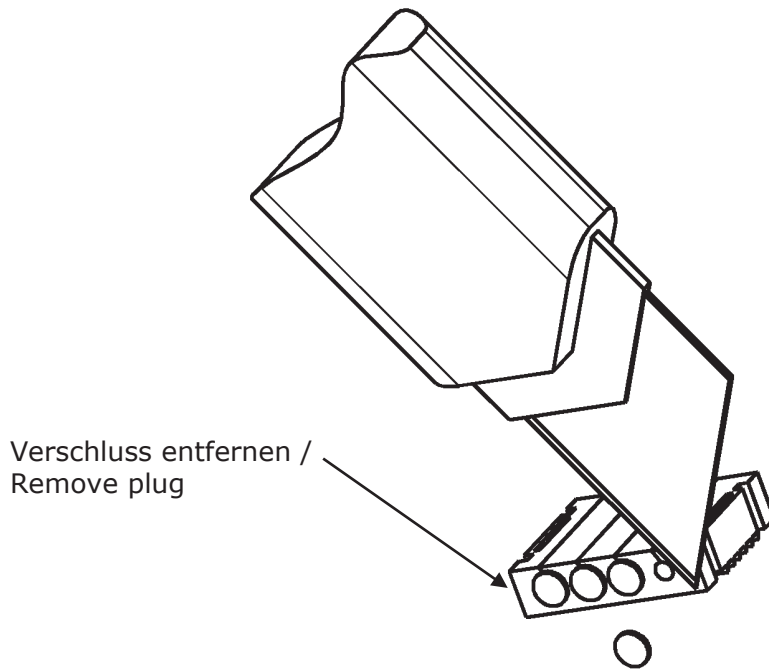

**Einführen der Dichtung für  
rückseitigen Zugang**

**Preparation of grommet for rear  
access**

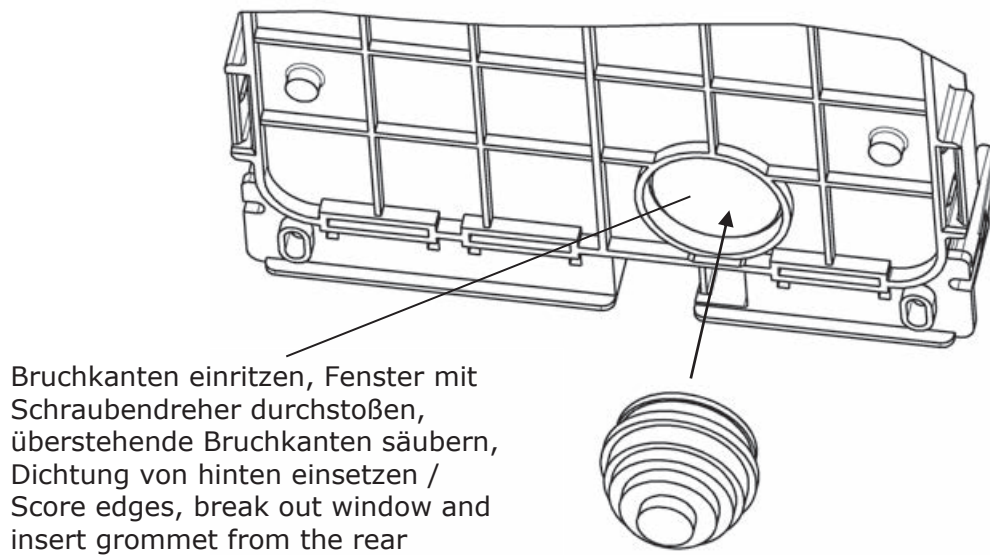

## Einsetzen der Zugentlastung

## Assembly of strain relief

Zugentlastung für Stich-  
und Durchschleiferkabel /  
Strain relief for drop and  
express cables

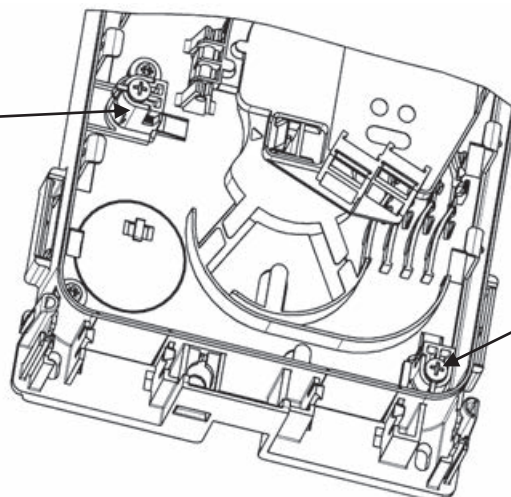

Zugentlastung für  
Rangierkabel /  
Strain relief for patch cords

Befestigung der  
Kabelseele / Securing  
cable strain relief

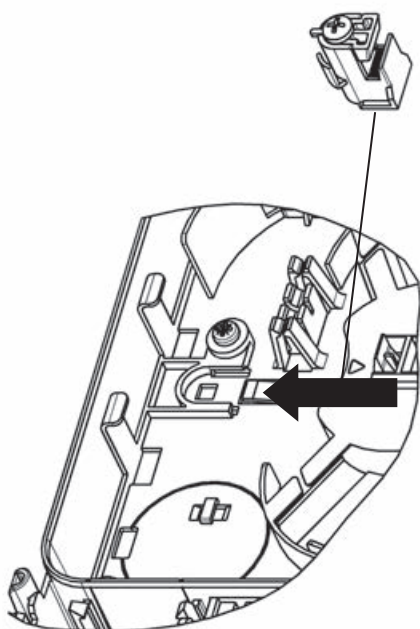

CLICK

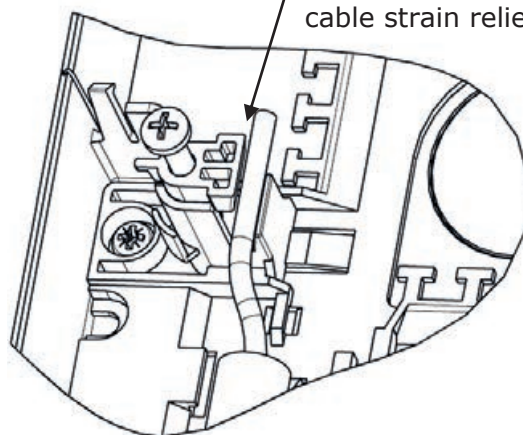

Befestigung von  
Aramidgarn / Fixing of  
aramid yarn

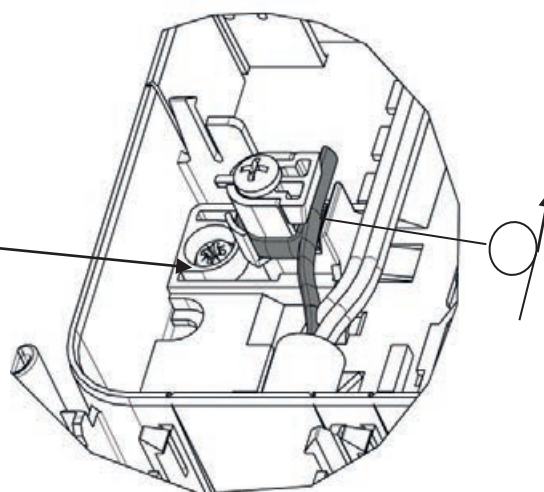

**Empfohlene Verlegung eines Durchschleifers**

**Recommended routing of express cable**

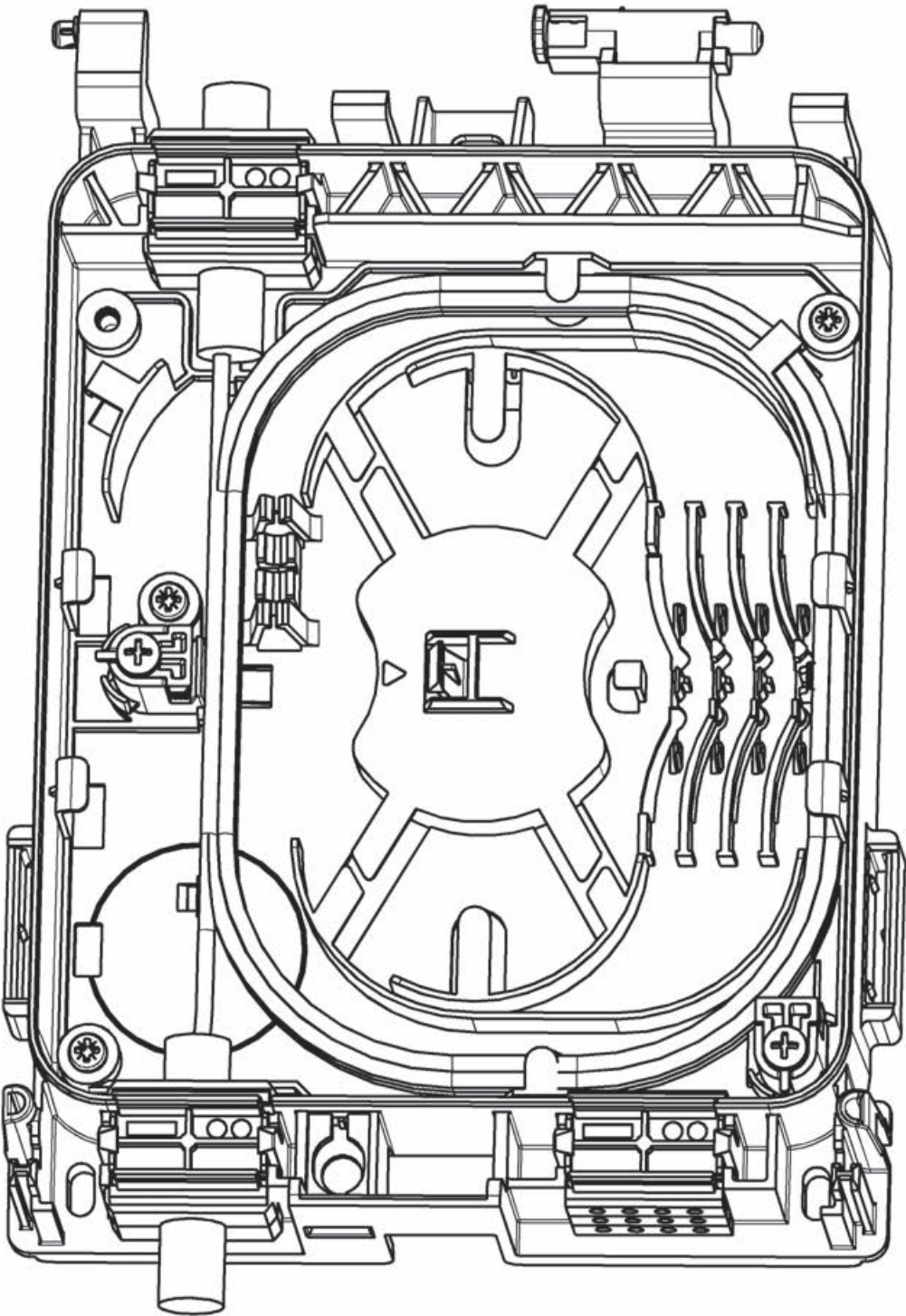

## Verlegung

## Routing

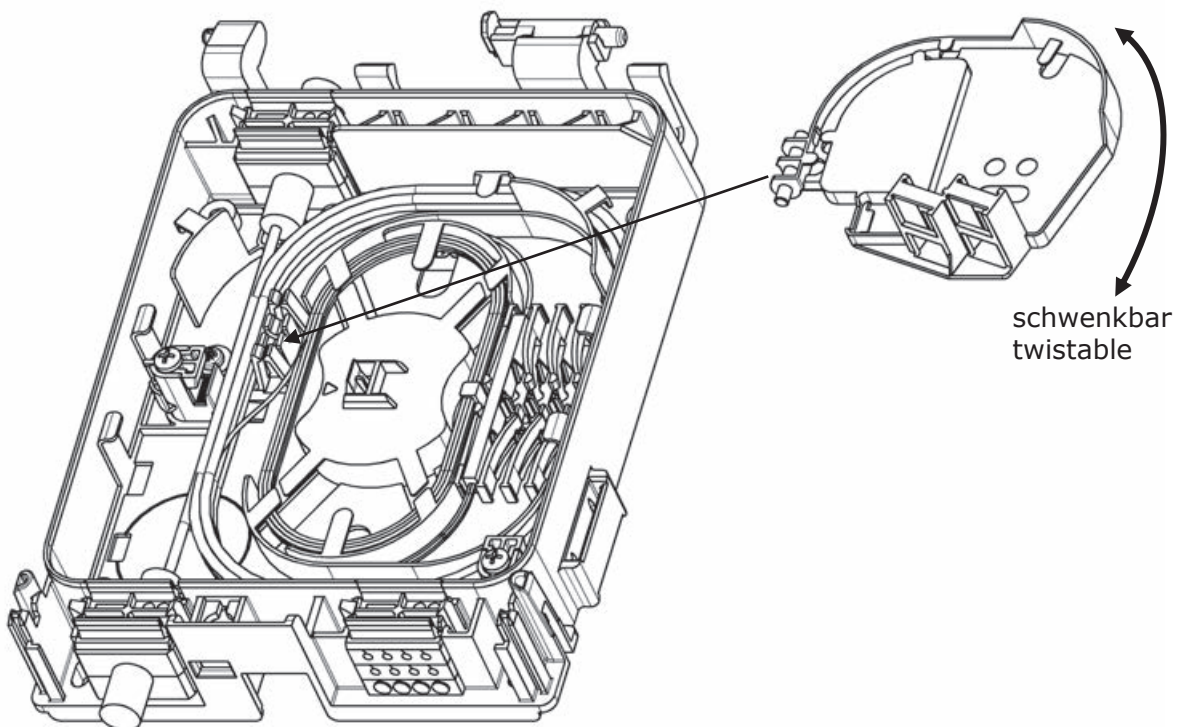
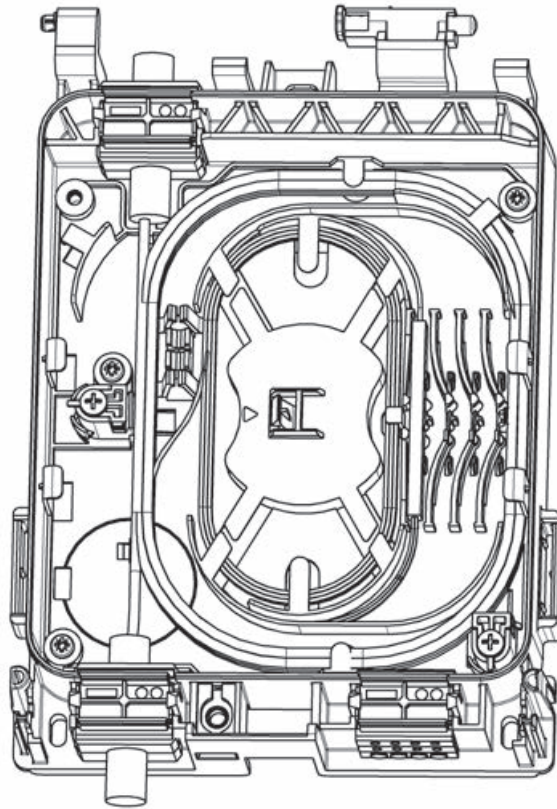

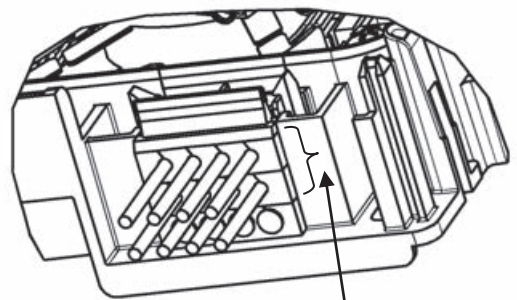
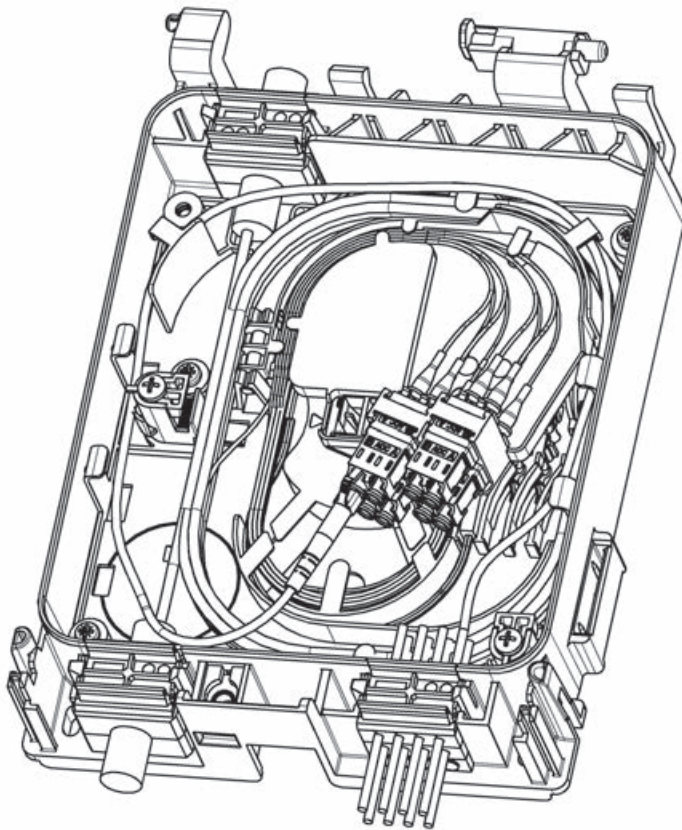
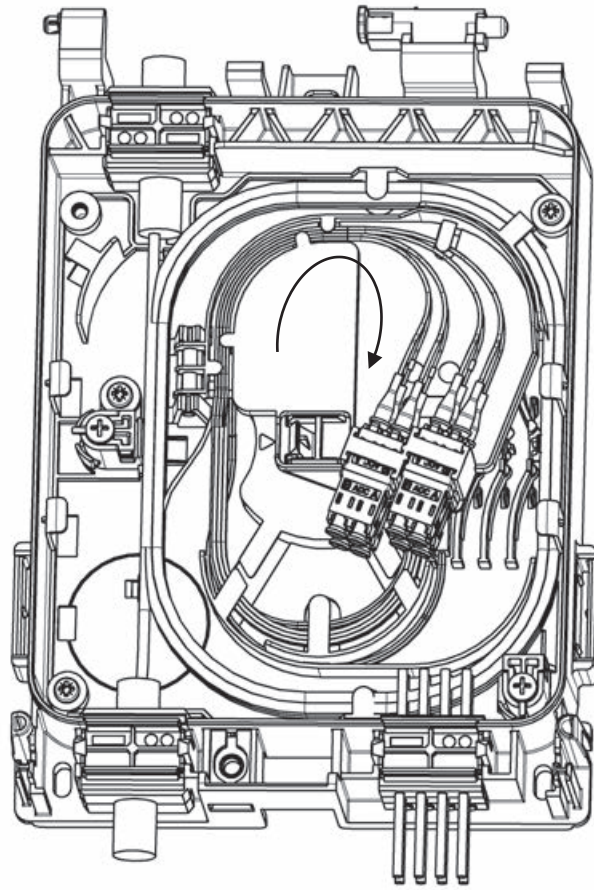

Bereich für Bestückung  
der Patchkabel /  
Layout area for patch cables





**Tyco Electronics Raychem bvba**  
**Diestsesteenweg 692**  
**B-3010 Kessel-Lo, Belgium**  
**Tel.: 32-16-351 011**  
**Fax: 32-16-351 697**  
**[www.te.com](http://www.te.com)**  
**[www.telecomnetworks.com](http://www.telecomnetworks.com)**

TE (logo) and TE Connectivity are trademarks of the TE Connectivity group of companies and its licensors.

While TE Connectivity and its affiliates referenced herein have made every reasonable effort to ensure the accuracy of the information contained in this catalog, TE Connectivity cannot assure that this information is error free. For this reason, TE Connectivity does not make any representation or offer any guarantee that such information is accurate, correct, reliable or current. TE Connectivity reserves the right to make any adjustments to the information at any time. TE Connectivity expressly disclaims any implied warranty regarding the information contained herein, including, but not limited to, the implied warranties of merchantability or fitness for a particular purpose. TE Connectivity' only obligations are those stated in TE Connectivity' Standard Terms and Conditions of Sale. TE Connectivity will in no case be liable for any incidental, indirect or consequential damages arising from or in connection with, including, but not limited to, the sale, resale, use or misuse of its products. Users should rely on their own judgment to evaluate the suitability of a product for a certain purpose and test each product for its intended application.