

Indoor fiber distribution box

1 Kit content

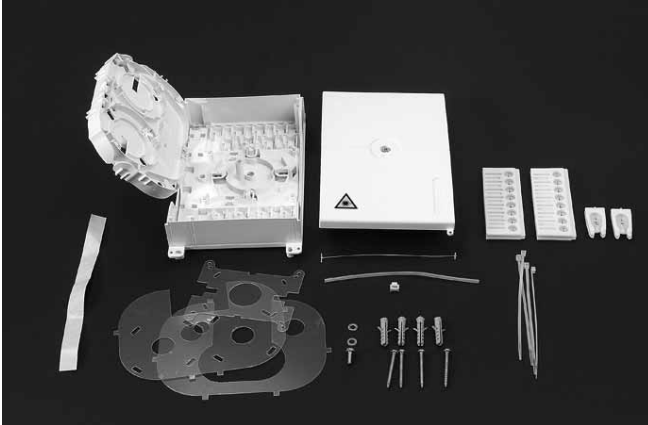

- Box
- Covers
- Cable seals
- Transportation tube
- Tie-wraps
- Snap fit

2 Kit for drop cables

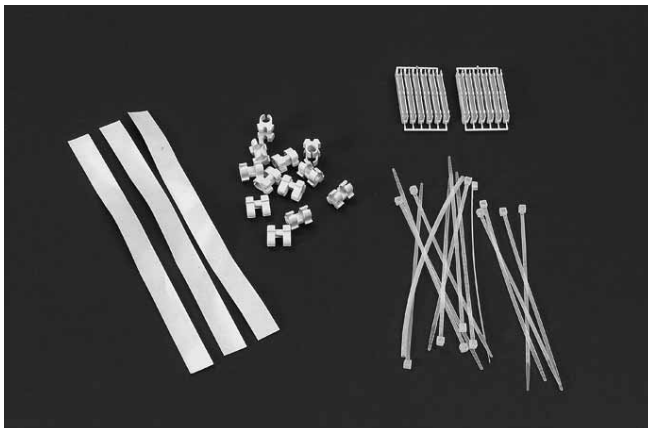

- Drop cable brackets
- Tie-wraps
- Foam strip
- Splice holder

3 General

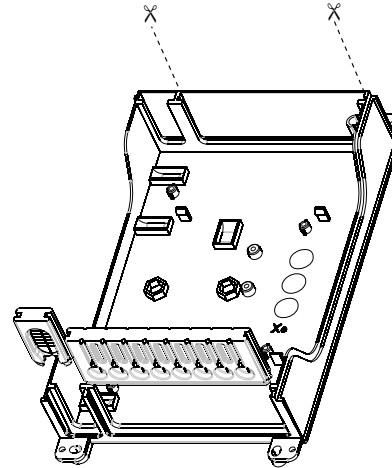

- 3.1 Break out the ports needed, For breaking out the ports, first cut with the scissor.

4 Preparation of the main cable

Note : solid lines are incoming fibers and dotted lines are representing customer side.

- 4.1 For looped cable, make a window cut by removing the outer jacket over a distance of 40 mm (in line) or 700 mm (butt). The fibers which will be used, need to be pulled up to 1500 mm.
- 4.2 Remove the inner tube by stripping/shaving up till 20 mm from the outer jacket.

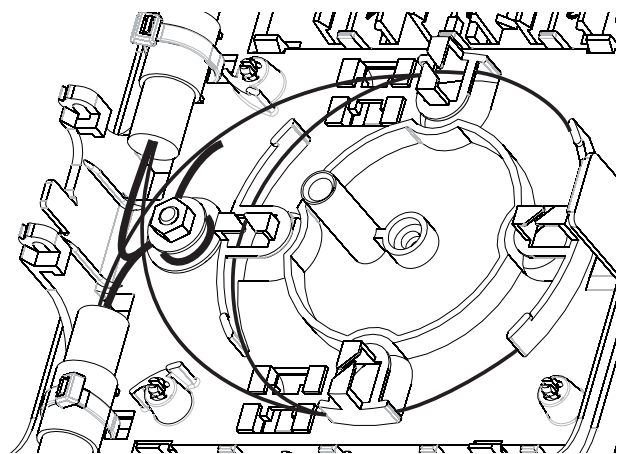

- 4.3 Cut the Kevlar over a length of 150 mm and terminate the Kevlar

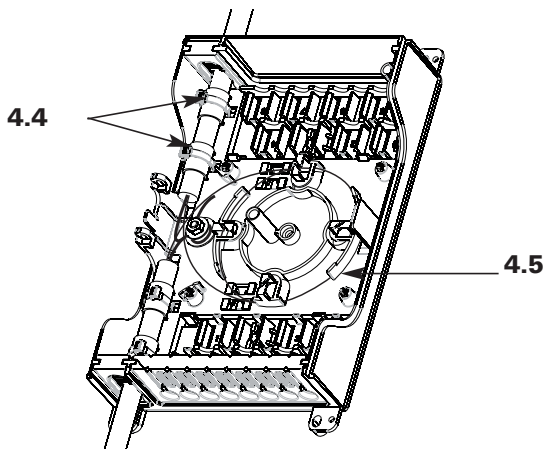

4.4 Wrap 1 layer of foam on the securing positions of the cable. Secure the cable with tie-wrap on this positions onto the box. Install the cable seals onto the cable.

Uncut fibers

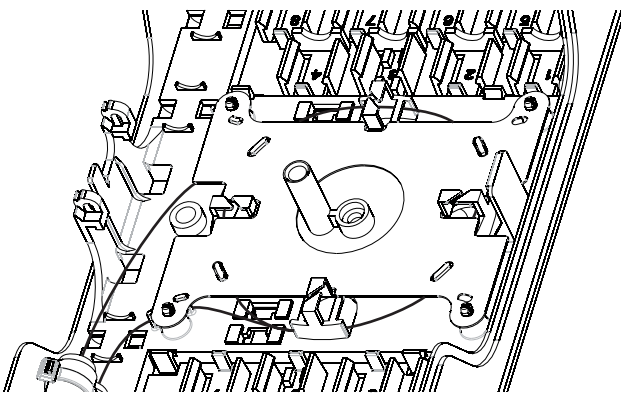

4.5 For the uncut fibers in the butt application storage can be done in the bottom of the box (max. 700 mm). Install the cover to protect these fibers.

Cut fibers (to be used later)

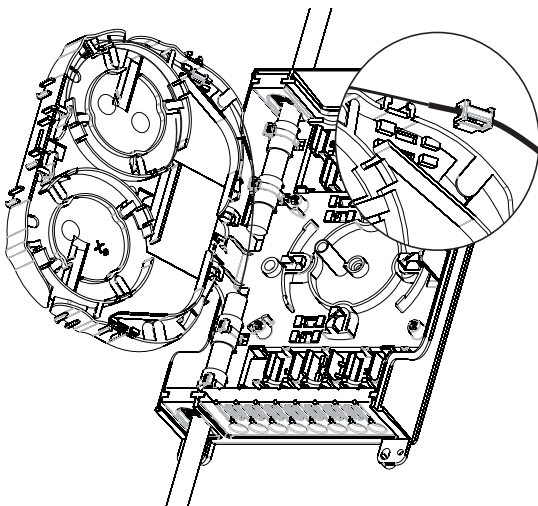

4.6 Install the transportation tube over the fibers. Slide the snap fit over the transportation tube. Lock the transportation tube into the securing position. Store the incoming fibers in the bottom side of the tray.

Cut fibers (to connect to the customer)

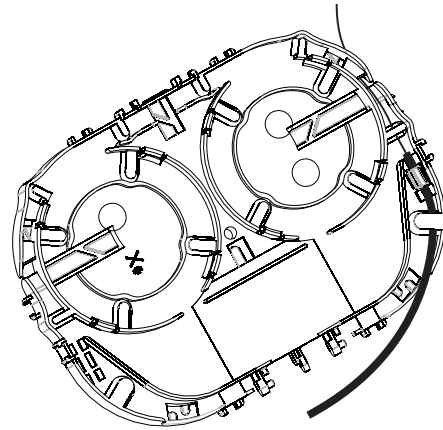

4.7 Separate the fibers from the ones to be stored and route these fibers to the top side of the tray.

5 Preparation of customer cable

5.1 Remove the outer jacket over a distance of 1500 mm.

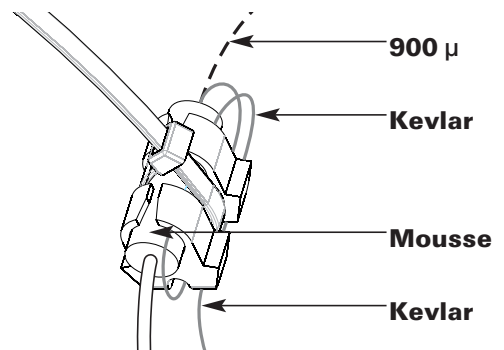

5.2 Wrap one layer of foam (20 mm) on the securing position if needed. Terminate the Kevlar by securing the cable/pigtail onto the bracket with tie-wrap. Depending the amount of Kevlar, it needs to be wrapped twice around the bracket.

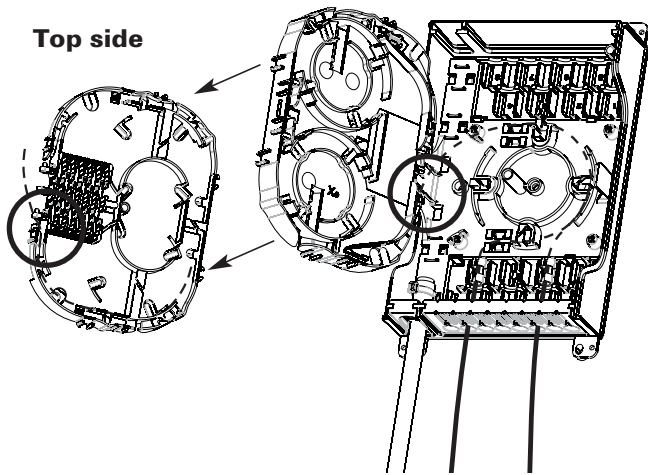

5.3 Cut the appropriate seal by using a scissor. First install the bracket starting from 1 to 4 following with 5 to 8. Route the 250/900 micron to the top side of the tray.

6 Connecting the customer

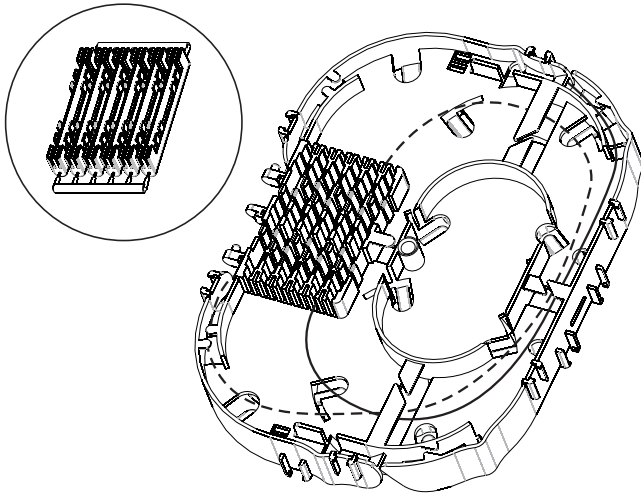

6.1 Install the splice in the splice holder and then store the overlength in the tray. Different splice protectors can be used.

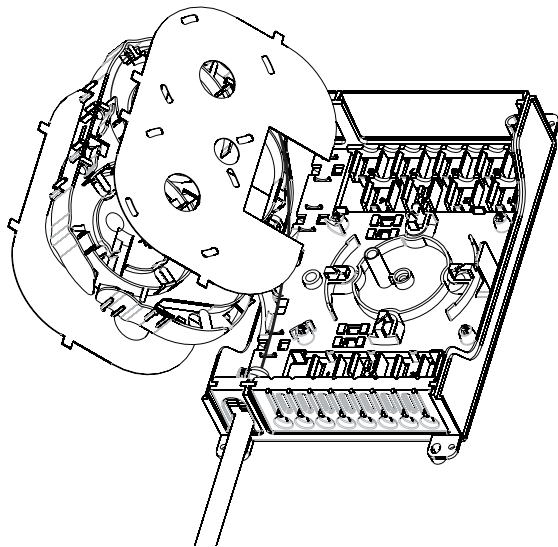

6.2 Install the covers (top/bottom) onto the tray.

7 Closing the box

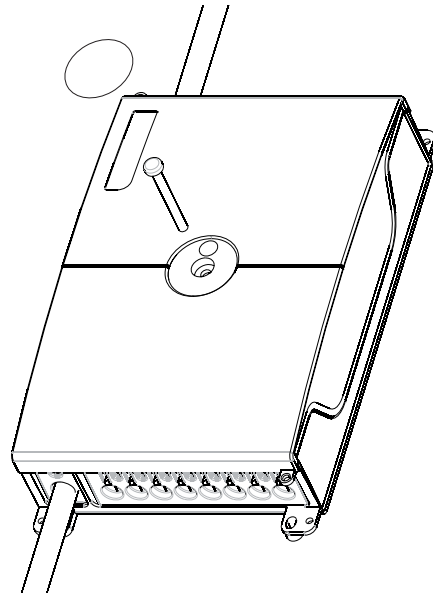

7.1 Secure the cover with the screw and seal with label (optional).

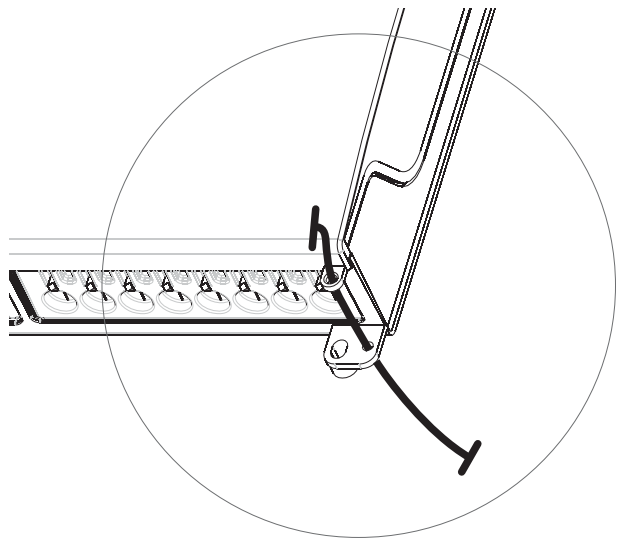

5.2 Install the nylon wire to connect cover and box.

Tyco Electronics Raychem NV

Diestsesteenweg 692
B-3010 Kessel-Lo, Belgium
Tel.: 32-16-351 011
Fax: 32-16-351 697
www.tycoelectronics.com
www.telecomsp.com

Tyco Electronics and TE logo are trademarks. Kevlar is a trademark of E.I. du Pont de Nemours.

The information given herein, including drawings, illustrations and schematics which are intended for illustration purposes only, is believed to be reliable. However, Tyco Electronics makes no warranties as to its accuracy or completeness and disclaims any liability in connection with its use. Tyco Electronics' obligations shall only be as set forth in Tyco Electronics' Standard Terms and Conditions of Sale for this product and in no case will Tyco Electronics be liable for any incidental, indirect or consequential damages arising out of the sale, resale, use or misuse of the product. Users of Tyco Electronics products should make their own evaluation to determine the suitability of each such product for the specific application.